



**TECHNICAL RULES
BAJAS**

2026

**RÈGLEMENTS TECHNIQUES
BAJAS**



Technical Rules Bajas

2026

Règlements Techniques Bajas

YEAR 2026		
Version	Applicable as from	Modified paragraphs
0	01.01.2026	25.03; 25.04; 01.46; 01.70;

Table of contents

01.01	INTRODUCTION.....	4
01.03	FREEDOM OF CONSTRUCTION	4
01.05	CATEGORIES AND GROUPS OF MOTORCYCLES	4
01.07	CLASSES	5
01.11	MEASUREMENT OF CAPACITY	7
01.17	SUPERCHARGING	8
01.18	TELEMETRY.....	8
01.19	MOTORCYCLE WEIGHTS	8
01.21	DESIGNATION OF MAKE	8
01.23	DEFINITION OF A PROTOTYPE	8
01.25	GENERAL SPECIFICATIONS	8
01.26	DEFINITION OF A FRAME OF A SOLO MOTORCYCLE	10
01.27	STARTING DEVICES	10
01.29	OPEN TRANSMISSION GUARDS	10
01.31	EXHAUST PIPES.....	10
01.33	HANDLEBARS.....	11
01.35	CONTROL LEVERS	13
01.37	THROTTLE CONTROLS	13
01.39	FOOTRESTS	14
01.41	BRAKES	14
01.43	MUDGUARDS AND WHEEL PROTECTION	14
01.45	STREAMLINING	15
01.47	WHEELS, RIMS, AND TYRES.....	15
01.55	NUMBER PLATES.....	16
01.56	LIGHTING, WARNING EQUIPMENT AND SPEEDOMETERS	18
01.58	ADDITIONAL SPECIFICATIONS FOR 450CC	18
01.59	ADDITIONAL* SPECIFICATIONS FOR QUADS	19
01.60	ADDITIONAL* SPECIFICATIONS FOR TRAILS	23
01.65	EQUIPMENT AND PROTECTIVE CLOTHING DURING PRACTICE AND RACE.....	26
01.67	WEARING OF HELMETS	28
01.69	HELMET OPERATIVE INSTRUCTIONS	29
01.70	RECOGNISED HELMET APPROVAL MARKS.....	30
01.75	BADGE OF THE FIM	30
01.76	NUMBER SASHES (BIBS).....	30
01.77	TECHNICAL VERIFICATIONS	31
01.78	DANGEROUS MACHINES	36
01.79	SOUND CONTROL.....	36
01.80	FUEL REGULATIONS	36

DIAGRAMS

Any references to the male gender in this document are made solely for the purpose of simplicity, and refer also to the female gender except when the context requires otherwise.

01.01 INTRODUCTION

The term motorcycle covers all vehicles having, in principle, less than four wheels, propelled by an engine and designed essentially for the carriage of one or more persons of which one is the rider of the vehicle. The wheels must normally be in contact with the ground except momentarily or in certain exceptional circumstances. Furthermore, in order to traverse certain surfaces one or all of the wheels can be replaced with skis, rollers or chains.

01.03 FREEDOM OF CONSTRUCTION

A motorcycle must conform to the requirements of the FIM regulations, to the Supplementary Regulations, as well as to a number of specific conditions that the FIM may require for certain competitions. No restriction is placed on the make, construction or type of motorcycle used.

All solo motorcycles (Group A) must be constructed in such a way that they are entirely controlled by a rider. Motorcycles with Sidecars (Group B) must be constructed to carry a passenger.

01.05 CATEGORIES AND GROUPS OF MOTORCYCLES

Motorcycles are divided into categories which must be observed for all meetings and world record attempts.

In principle, it is forbidden for different categories, groups and classes to compete in the same race, unless the Supplementary Regulations state otherwise.

Category I

Motorcycles propelled by the action of one wheel in contact with the ground.

Category II

Special vehicles propelled by the action of one or two wheels in contact with the ground but which are not covered by the conditions of Category I.

Group A1 - Solo Motorcycles

2-wheel vehicles making only one track on the ground.

Group B1

Vehicles with three wheels, making two tracks on the ground, consisting of a motorcycle making one track and a sidecar for a passenger making the other track.

Group B2

Vehicles with three wheels, making two or three tracks on the ground in the direction of forward travel, with a permanently attached Sidecar forming a complete integral unit.

If three tracks are made, the centre-lines of the two tracks made by the motorcycle wheels must not be more than 75 [mm] apart. A track is determined by the longitudinal centre-line of each of the vehicle's wheels in the direction of forward travel.

Category III

Vehicles propelled by the action of multiple driving wheels in contact with the ground in only one direction.

Group C - Special 2 wheel driven motorcycles

Group D - Special 3 wheel, 2 wheel driven motorcycles

Group E - Snowmobiles

Group F - Sprinters and Dragsters

Group G - Quad racers (propelled by the action of two wheels)

Group H - Quad racers (propelled by the action of four wheels)

01.07 CLASSES

Groups are again separated into classes according to cylinder capacities as detailed below. Generally, these classes must be observed for all meetings.

See also Arts. 80.7.1 of the 2026 FIM Bajas World Championship Regulations, for details.

Category I

Group A1 - Solo Motorcycles

Class (cc)	over (cc)	up to(cc)
50	-	50
80	50	85

100	85	100
125	100	125
175	125	175
250	175	250
450	250	450
500	450	500
750	500	750
1000	750	1000
1300	1000	1300
Class (cc)	over (cc)	up to(cc)

Groups B1, B2 - Sidecars

Same as groups A1 and A2 over 175 cc.

Category II

Same classes as Category I, Group A1.

Category III

Same classes as Category I, Group A1.

**Please refer to Art. 82.7.1 Categories, Groups, Classes and Trophy of the 2023 FIM Bajas World Cup Regulations.
(extract hereunder)*

All motorcycles will be according to Category I, Group A1 and Category II, Group C (Art. 01.07), with the following specifications:

07.01 Categories/Groups/Classes are as follows:

- Category 1: Motorcycle (Up to 450cc)
- Category 2: Quad
- Category 3: SSV World Cup (Up to 1050cc) – (Art. 01.59 60)
- Category 4: Trail – (Art. 01.60)

The following Classes will be implemented in Category 1 and 2*:

- Class 1: Women World Cup
- Class 2: Junior World Cup
- Class 3: Veteran Trophy

01.11 MEASUREMENT OF CAPACITY**11.11 Reciprocating movement engine, "Otto" Cycle**

The capacity of each engine cylinder is calculated by the geometric formula which gives the volume of a cylinder; the diameter is represented by the bore, and the height by the space swept by the piston from its highest to lowest point:

$$\text{Capacity} = \frac{D^2 \times 3.1416 \times C}{4}$$

where D = bore
and C = stroke

When a cylinder bore is not circular the cross sectional area must be determined by a suitable geometrical method or calculation, then multiplied by the stroke to determine capacity.

When measuring, a tolerance of 1/10 [mm] is permitted in the bore. If with this tolerance the capacity limit is exceeded for the class in question, a further measurement should be taken with the engine cold, to 1/100 [mm] limits.

11.13 Rotary engines

The capacity of an engine which determines the class in which the motorcycle shall compete in a meeting shall be calculated by:

$$\text{Capacity} = \frac{2 \times V}{N}$$

where V = total capacity of all the chambers comprising the engine
and N = number of turns of the motor necessary to complete one cycle in a chamber.

This engine is classified as a 4-stroke.

11.15 Wankel system

For Wankel system engines with a triangular piston, the capacity is given by the formula:

$$\text{Capacity} = 2 \times V \times D$$

where V = capacity of a single chamber
and D = number of rotors

This engine is classified as a 4-stroke.

01.17 SUPERCHARGING

Supercharging by means of a device of any kind is forbidden in all meetings.

An engine whether 2-stroke or 4-stroke coming within any one of the recognised classes (determined by the capacity of the working cylinder) shall not be considered as supercharged when in respect of one engine cycle, the total capacity measured geometrically, of the fuel charging device or devices, including the capacity of the working cylinder (if used for injecting the fuel), does not exceed the maximum capacity of the class in question.

01.18 TELEMETRY

Information must not be transmitted in any way to or from a moving motorcycle.
An official signalling device may be required on the machine.
Automatic lap timing devices are not considered as “telemetry”.
Automatic lap timing devices must not disrupt any official time keeping methods and equipment.

01.19 MOTORCYCLE WEIGHTS

At present, there are no minimum weight limits for motorcycles.

01.21 DESIGNATION OF MAKE

When two manufacturers are involved in the construction of a motorcycle the name of both must appear on the machine as follows:

- The name of the chassis manufacturer
- The name of the engine manufacturer

01.23 DEFINITION OF A PROTOTYPE

A prototype motorcycle is a vehicle which must conform to the safety requirements as required by the FIM Sporting Code and Appendices applicable to the type of competition for which it is to be used.

01.25 GENERAL SPECIFICATIONS

The following specifications apply to all vehicles of the groups indicated and to all types of competitions except where otherwise stated in the corresponding section of the FIM Sporting Code.

They should also be applied to all national competitions unless the FMNR (National Motorcycling Federation) has otherwise directed.

Further specifications for some competitions may also be required and these will be detailed in either the appropriate FIM Appendix or in the Supplementary Regulations for the competition in question.

All vehicles from the 450cc and Quad categories must conform in all respects to the 1968 Vienna Convention, even if the country in which the machine was manufactured is not a signatory to that Convention, and be registered for road use.

These vehicles are based on series production motorcycles, which can be modified and/or equipped for off-road competition.

The main parts: frame, engine (cylinder, cylinder head and crankcase) and swing-arm (this latter only for 450cc) used must be a standard component, and must be freely available to the public. These main parts, with the exception of the crankcase, may be modified but must fulfil the FIM Bajas Technical Rules.

Concerning material verification, in case of doubt, a sample or the part in question shall be taken and analysed at a Material Testing laboratory.

25.01 Use of titanium

The use of titanium in the construction of the frame, the front forks (referred only to structural parts: legs, tubes, etc), the handlebars, the swinging arms, the swinging arm spindles and the wheel spindles is forbidden.

The use of light alloys for wheel spindles is also forbidden.

The use of titanium alloy nuts and bolts is allowed.

25.03 Carbon fibre

The use of carbon fibre reinforced materials is authorised (with the exception of handlebars, wheels ~~rims~~, **main frame, swingarm**).

25.04 Ceramic materials

~~The use of ceramic parts is forbidden.~~

The use of ceramic parts is allowed for the following parts:

- **Clutch plates**
- **Bearings (clutch, wheels, etc.)**
- **Spark plug**
- **Air fuel ratio sensor (Lambda)**
- **Throttle sensor assembly**

NB: The quality and the mechanical properties/resistance of the ceramic parts mounted by the rider/team on their machine remains under their full responsibility.

25.05 Other equipment

No signal of any kind may pass between a moving motorcycle and any person, including radio and Bluetooth communication. The exception is for the signal from the time keeping transponder, the tracking system as provided by the Organiser, automatic lap timing devices or approved on-board cameras (with prior written approval from the Championship Promoter/Organiser, which cannot be granted for helmet mounted cameras).

25.06 Number of cylinders

The number of cylinders in an engine is determined by the number of combustion chambers.

25.07

If separate combustion spaces are used they must be connected by an unrestricted passage of minimum cross sectional area at least 50% of the total inlet port area.

01.26 DEFINITION OF A FRAME OF A SOLO MOTORCYCLE

The structure or structures used to join any steering mechanism at the front of the machine to the engine/gear box unit and to all components of the rear suspension.

26.01

Every motorcycle in the 'parc-fermé' must be equipped with a side-stand. The side-stand must be fitted, either on the frame or on the swing arm.

01.27 STARTING DEVICES

Starting devices for the engine are compulsory.

01.29 OPEN TRANSMISSION GUARDS

29.01

A guard must be fitted to the countershaft sprocket.

29.02

A chain guard must be fitted in such a way to prevent trapping between the lower chain run and the final driven sprocket at the rear wheel.

01.31 EXHAUST PIPES

Exhaust pipes and silencers must fulfil all the requirements concerning sound control (see also Art. 01.79).

31.01

The axis of the silencer end must be parallel (tolerance 15°) to the two principal longitudinal planes of the vehicle. The extremity of the silencer must not pass the vertical tangent of the rear tyre.

31.02

The edge of the silencer shall not be dangerous in case of accidental contact with the riders or helpers. In case of quads, the exhaust pipe of the silencer must be protected by a rounded edge of minimum 4 [mm].

31.03

Exhaust fumes must be discharged towards the rear but not in such a manner as to raise dust, foul the tyres or brakes, or inconvenience the passenger (in the case of sidecars), or any other rider.

31.04

On a Sidecar machine the exhaust must discharge horizontally and towards the rear, at a maximum angle of 30° to the axis of the machine.

31.05

Any NON-ORIGINAL valve systems installed on the exhaust system with a view to influencing (or modifying) the sound level meter test is forbidden. Only exhaust valve systems (e.g. Exup) provided by the manufacturer on the manifold are authorised. The setting is free.

01.33 HANDLEBARS**33.01**

The width of handlebars must be not less than 600 [mm] and not more than 850 [mm]. (see Figure 1)

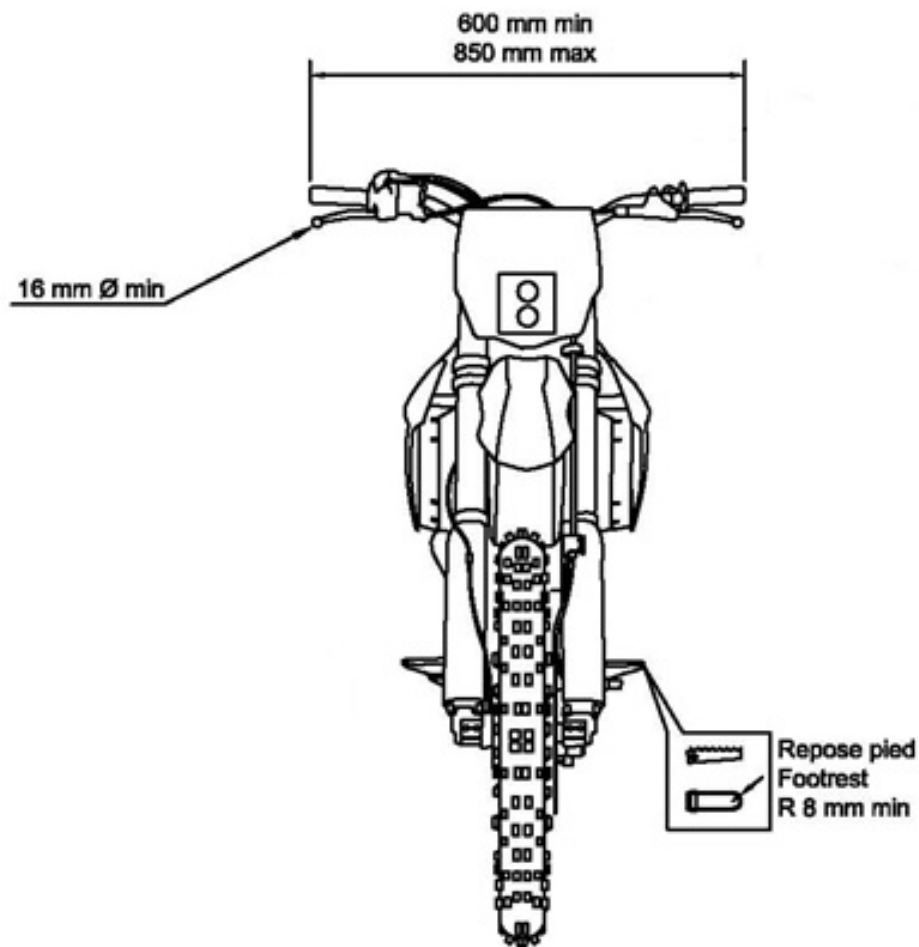

Figure 1

33.02

The handlebars must be equipped with a protection pad on the cross bar. Handlebars without a cross member must be equipped with a protection pad located in the middle of the handlebars, covering widely the handlebars clamps.

33.03

Handlebar clamps must be very carefully radiused and engineered so as to avoid any fracture points in the handlebar.

33.04

Exposed handlebar ends must be plugged with a solid material or rubber covered.

33.06

When hand protectors are used, these must be made of a shatter-resistant material and have a permanent opening for the hand.

33.07

Handlebars made of composite materials are not authorised.

33.08

Repair by welding of light alloy handlebars is prohibited.

33.09

Solid stops (when on full-lock, other than steering dampers) must be fitted. These must ensure a minimum clearance of 30 [mm] between the handlebar with levers and the tank to prevent trapping the rider's fingers.

01.35 CONTROL LEVERS**35.01**

All handlebar levers (clutch, brake, etc.) must be in principle ball ended (diameter of this ball to be at least 16 [mm]). This ball can also be flattened, but in any case, the edges must be rounded (minimum thickness of this flattened part 14 [mm]). These ends must be permanently fixed and form an integral part of the lever. If the gear lever consists of a tube, then its edge must be rounded.

35.03

Each control lever (hand and foot levers) must be mounted on an independent pivot.

35.04

The brake lever if pivoted on the footrest axis must work under all circumstances, such as the footrest being bent or deformed.

01.37 THROTTLE CONTROLS**37.01**

Throttle controls must be self-closing when not held by the hand. All air intakes into the cylinder must pass through the throttle body. No other means allowing ambient air into the inlet track of the cylinder head are allowed.

37.03

Solo motorcycles must be equipped with a functional ignition kill switch or button mounted on either right or left side of handlebar (within reach of the hand while on the hand grips), that cut the power to the engine.

Quads must be equipped with a safety ignition cut-out switch which must be permanently attached to the rider right wrist by a non-elastic, spiral cable, as short as possible.

01.39 FOOTRESTS

Footrests must be solidly fixed or of a folding type but in this case must be fitted with a device which automatically returns them to the normal position, and an integral protection is to be provided at the end of the footrest which must have at least 8 [mm] radius (see Figure 1). The footrest teeth shall not be sharp. The height of the footrest teeth must be 10 [mm] maximum.

01.41 BRAKES

41.01

All motorcycles must have at least 2 efficient brakes (one on each wheel, front and rear) operated independently and operating concentrically with the wheel.

41.02

Vehicles in Group B must be fitted with at least 2 efficient brakes operating on at least 2 of the wheels and be operated independently.

01.43 MUDGUARDS AND WHEEL PROTECTION

Motorcycles must be fitted with mudguards.

43.01

Mudguards must project laterally beyond the tyre on each side.

43.02

The front mudguard must cover the angle formed by one line drawn from the front edge of the mudguard to the centre of the wheel and one drawn horizontally through the centre of the wheel must be maximum 60°.

43.03

The rear mudguard must cover the angle formed by two lines, one drawn from the rear edge of the mudguard to the centre of the wheel and one drawn horizontally through the centre of the wheel shall not exceed 70°. (See Figure 2)

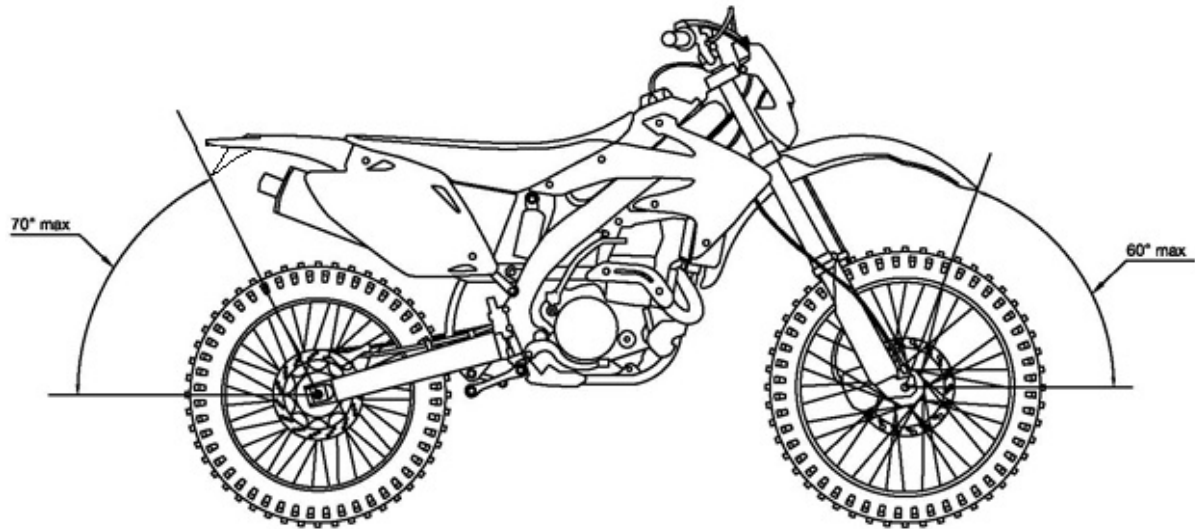

Figure 2

01.45 STREAMLINING

A 'full' fairing or 'complete' bodywork is not allowed.

Radiator covers (shields) must be made of flexible materials only (e.g. plastics).

01.46 SUSPENSION

Electronically **or electrically** controlled suspension systems must not be used.

01.47 WHEELS, RIMS, AND TYRES

47.01

All tyres will be measured mounted on the rim at a pressure of 1 [kg/sq.cm] (14 [lb./sq.in]); measurements are taken at a tyre section plane with a 90° angle with the ground plane.

47.02

Any modification to the rim or spokes of an integral wheel (cast, moulded, riveted) as supplied by the manufacturer (other than for rims with spokes, or valve and security bolts) is prohibited, except for tyre retention screws sometimes used to prevent the tyre movement relative to the rim. If the rim is modified for these purposes, bolts, screws, etc., must be fitted.

47.03

The front and rear tyre dimensions are free with reference to diameter and width.

47.04

Tyres with metal studs, spikes, chains or any other anti-skid devices are not permitted. Scoop or paddle tyres (continuous radial rib) are forbidden.

47.05

Only tyres normally available from commercial or retail sources are authorised.

Modifying the tyre is not authorised. It is forbidden to treat tyres with chemicals, cut or groove them, use tyre warmers or any other means which may alter the shape, minimum Shore hardness, construction or other characteristics.

The tyres shall appear on the tyre manufacturers range catalogue or tyre specification lists available to the general public.

They shall be approved according to UN Vehicle Regulation 75 Rev. 2 (2010) with the following specific features:

- Category of use (5.2): it shall be "snow" or "special" or "All terrain"
- Speed category symbol (5.4): M (130 Km/h) or above
- Load capacity index (5.5): 45 (165 Kg) or above.

It is recommended that the tyres be used according to the European Tyre and Rim Technical Organisation (ETRTO) guidelines.

The E approval mark and number as defined by the UN Vehicle Regulation R75 must be present on both the front and rear tyre sidewalls.

The DOT approval mark is also accepted.

Any marking on the tyre reporting "FIM" approved or similar is forbidden for new production dates (from 2018). FIM Quality Products are exempt of this rule.

47.06

The tread pattern specifications of the rear tyre are free. However, Art. 47.05 applies in full.

47.07

The number of tyres is limited to one set (front(s) and rear(s)) per race day. When the day is composed of several stages, the tyres could be marked by the FIM Technical Director and/or his appointed crew.

01.55 NUMBER PLATES

Number plates are required for Bajas.

The Organiser shall provide each rider with a set of identification plates comprising 1 front plate and 2 side plates called number plates. The exact sizes and positions of these number plates will be explained in the SR.

The number plates shall be affixed visibly at the front and on the rear sides of the motorcycle. They shall in no circumstances cover, throughout the duration of the Baja, even partly, the registration number of the motorcycle.

55.07

The figures must be clearly legible and like the background must be painted in matt colours to avoid reflection from sunlight. The minimum dimensions of the letters being:

- Height of the number 140 [mm]
- Width of figure 80 [mm]
- Width of the stroke 25 [mm]
- Space between two figures 15 [mm]

55.08

The English form for numbers must be used. That is single vertical line for the "one" and a simple sloping line without a horizontal line for the "seven". (See Diagram O).

55.09

All other number plates or markings on a motorcycle liable to cause confusion with the number must be removed before the start of a competition.

55.12 Number plate colours

The number plates for the FIM Bajas World Cup shall be as follows:

Class	Background colour	Number colour
450cc	White	Black
Quads	White	Black
Women	Purple	White
Trail	White	Black

The colours must be matt, following the RAL colour table, example :

YELLOW	1003
RED	3020
PURPLE	4006
BLUE	5005
GREEN	6002
BLACK	9005
WHITE	9010

Regarding Support races/classes:

The colour of the number plates will be left at the discretion of the Organiser and will be specified in the SR's.

55.13

In case of a dispute concerning the legibility of numbers, the decision of the Technical Steward will be final.

01.56 LIGHTING, WARNING EQUIPMENT AND SPEEDOMETERS

Motorcycles and their equipment must comply with the national legal requirements for road traffic of the country in which the vehicle is registered and with other rules specified in the Supplementary Regulations.

The original headlights and rear lights may be modified or replaced. Extra lights may be added.

The electric generator must operate continuously and normally with respect to current and voltage requirements to run front and rear lights during the competition and at post competition control. The electrical connections must be retained.

01.58 ADDITIONAL SPECIFICATIONS FOR 450CC

These vehicles are registered (allowed to be used on roads open to traffic) and can be modified and/or equipped for Bajas competition.

All motorcycles will be according to Art. 01.07.

58.01 Engine capacity

450cc category:

Single cylinder engines up to 450cc 2T or 4T

58.02 Engine

The engine number must remain visible at all times.

Engine preparation is free

During the event, an “engine change” means removing the engine from the frame. Engine “A”, originally fitted in the frame of the bike can be removed from the frame to be repaired and be replaced by engine “B”. Engine “A” may be repaired during the Event on condition that the engine crankcase marked during the preliminary technical inspection remains the same.

Repairs to the engine's "top end" (cylinder + cylinder head) are free during the event. All intervention to the "bottom-end" (inside the crankcases) will be considered as a change of engine.

A minimum of one bolt/nut used to fix the engine must be drilled in order to attach a seal embracing the frame.

The engine may be removed from the frame to repair a problem not related to the crankcase. This may be done only under the supervision of the Technical Steward. The Technical Steward only can cut and replace the seals without being penalised.

58.03 Frame and ancillaries

The main frame must be marked with the original Vehicle Identification Number (VIN). The frame number (VIN) must remain visible at all times.

The frame shall not be replaced during the event. The frame may be repaired under the supervision of the Technical Steward.

01.59 ADDITIONAL* SPECIFICATIONS FOR QUADS

*The present Art. 01.59 prescribes additional rules for Quads, while the rest of the book applies.

These vehicles shall be registered (allowed to be used on roads open to traffic).

Top speed is limited to 130km/h

Quads are set in two Groups :

01.59.1 Group G/ Quad Racers: propelled by the action of two wheels (2 wheel driven).

Engine must be produced in a series and available on the market. Cylinder, cylinder head may be modified, with the exception of the crankcase, but must fulfil the FIM Technical Rules for Cross-Country Rallies Quads category.

The chassis must be produced in a series and available on the market, only competition related modifications are permitted. Chassis and engine must match. In case of a dispute, the decision of the Chief Technical Steward/ FIM Technical Director will be final.

01.59.2 Group H/ Quad Racers: propelled by the action of four wheels (4 wheel driven).

Refer to Article 01.07 Classes for definition.

The engine minimum production quantities for engines shall be: 200 units*

*The minimum required production quantities refer to units with identical equipment.

Evidence of engine production quantities may be required by FIM, certified by the manufacturer's auditing firm and/or any other institution which may provide reliable documentation written in English.

59.01 Engine capacity

Group G:

- from 250cc up to 350cc for two cylinder, 2-stroke engines
- up to 500cc for single cylinder, 2-stroke engines
- up to 750cc for single cylinder, 4-stroke engines.

Group H:

- up to 1000cc for single or twin cylinders, 4-stroke engines.

59.02 Engine

The engine must be produced from a recognised and FIM licenced manufacturer.

The engine number (stamped on the crankcase) must remain visible at all times.

The following engine specifications and components may be altered from the original model:

- 1) Cylinder head:
Intake and exhaust tracts surfaces may be polished. No addition of material is allowed.
The gasket is free and compression ratio can be modified.
- 2) Camshafts and camshaft sprockets are free.
Valve springs can be replaced but titanium springs are forbidden.
- 3) Pistons, pistons rings, pins and clips: may be altered or replaced from those fitted to the engine.
- 4) Exhaust system:
Exhaust pipes and silencers may be altered or replaced.
- 5) Clutch: An aftermarket or modified clutch is permitted.
- 6) Radiator and/or oil cooler may be altered or replaced, additional radiators and oil cooler may be added.
- 7) Oil pumps and oil liners may be altered or replaced. Oil lines containing positive pressure, if replaced, must be of metal reinforced construction with swaged or treaded connectors.
- 8) Oil tanks may be added or modified.

- 9) Air filter may be altered or replaced.
- 10) Fuel pump may be modified or replaced.
- 11) Ignition / Engine Control System (ECU), hardware and software may be modified or changed.
- 12) Generator, alternator, electric starter may be modified or replaced.
- 13) Secondary transmission is free.

During the event, an 'engine change' means removing the engine from the frame. Engine 'A' originally fitted in the frame of the bike can be removed from the frame to be repaired and be replaced by engine 'B' Engine 'A' may be repaired during the event on the condition that the engine crankcase(s) marked during the preliminary technical inspection remain(s) the same.

Repairs to the engine's 'top end' (cylinder + cylinder head) are free during the event. All intervention to the 'bottom-end' (inside the crankcases) will be considered as a change of engine.

A minimum of one bolt/nut used to fix the engine must be drilled in order to attach a seal embracing the frame.

The engine may be removed from the frame to repair a problem not related to the crankcase. This intervention may be done only after formal request and under the supervision of the Technical Steward. Only the Technical Steward can cut and replace the seals without the participant being penalised.

59.03 Steering

The machine can operate on the front wheels only.

59.04 Chassis and ancillaries

Shock absorbers and associated springs are free.

Wheelbase, front and rear track are free but the overall width is defined by Art. 59.11.

The main chassis must be marked with the original Vehicle Identification Number (VIN). The frame number (VIN) must remain visible at all times.

The chassis shall not be replaced during the event. The frame may be repaired under the supervision of the Technical Steward.

For Group H only:

The main chassis may only be altered by addition of material, no material can be removed (except original engine fixing points if an alternative unit is installed).

The position on the chassis of steering pipe, swing arm, suspension linkage mounting points must remain as in the production Quad.

The rear sub-frame can be modified, but the type of material must remain as in the production model and the weight cannot be lower.

Fairing and body can be modified or replaced.

Seat may be modified or replaced.

Battery may be changed but the nominal energy must be equal or higher than the original one.

Footrests and foot controls may be modified or replaced.

59.05 Number plates

Four number plates are required:

- 1 plate fixed to the front of the machine at the level of the head lamp, facing forward.
- 1 double-side rear plate made of flexible material set on the safety bar placed behind the saddle of the quad.

59.06 Suspensions

All the mountings of the front and rear suspension units, suspension arms and the steering spindle are retained by a safety wire or a splitpen.

For Group H only:

Steering linkages and suspension arms may be modified or replaced. The FIM may require demonstrating that the new parts present equivalent or higher mechanical properties to the original ones.

59.07 Brakes, wheels and rims

Disc brakes, callipers and associated pipes can be changed.

The rear wheel rim diameter cannot exceed 12 [inches] in Group G and 15 [inches] in Group H. Wire spokes are not authorised.

Every front wheel must have a single, functional brake installed on each axle and be operated by a handlebar mounted lever.

At the rear, the vehicle must have a brake on each wheel or a brake installed jointly on the rear wheel axle, operated either by a lever on the handlebar or by a foot pedal.

Wheels may be replaced but not modified. Magnesium alloys and carbon-reinforced wheels are forbidden.

59.08 Mudguards

The front and rear wheels must be covered by mudguards made of flexible materials, covering each wheel over an area of minimum 30 degrees.

59.09 Fuel tank(s)

Supplementary fuel tanks are allowed but must be at least 25 [mm] (1 [inch]) away with relation to the edges of the protective barrier.

Original fuel tanks can be modified or replaced but the fixing points on the chassis and the fixing system must be as in the original model. Supplementary fuel tanks are allowed.

Fuel tank(s) attached to the handlebar are strictly forbidden.

59.10 Protection (Diagram Q)

The secondary chain transmission must be equipped with a cover/shield protecting both the chain sprocket and the brake disc.

A compulsory countershaft sprocket guard must cover the sprocket by 30% minimum and prevent the rider's hand/foot becoming trapped.

The complete length of the lower chain run must be shielded by a guard or a protection tube, securely fixed.

A crash 'bar' or 'guard' must be fixed at the front and the rear of the vehicle.

A protective barrier (or 'guard') of a round profile (minimum diameter: 25 [mm] or 1 [inch]) must be installed on each side of the vehicle. This protective barrier must be fitted in such a way that it is in alignment with the wheels to eliminate entanglement. There shall be no prominent (sharp) parts.

A structure of crossed belts or a metallic grid must be fitted to fill the opening between the wheels and the barrier, to prevent the riders' foot from accidentally touching the ground.

59.11 Dimensions

The width cannot exceed **1350** ~~1300~~ [mm] for group G and 1450 [mm] for group H. The maximum height at the rider's seat level is 950[mm] for group G and 1100 [mm] for group H (with all liquids at operational level and full fuel tank, and without the rider).

01.60 ADDITIONAL * SPECIFICATIONS FOR TRAILS

*The present Art. 01.60 prescribes additional rules for Trails, while the rest of the book applies.

These vehicles shall be registered (allowed to be used on roads open to traffic).

Top speed is limited to 130km/h

60.01 Engine capacity

The minimum engine capacity is 600cc, twin cylinder or more.

60.02 Engine

The engine must be produced from a recognised and FIM licenced manufacturer.

The engine number (stamped on the crankcase) must remain visible at all times.

The following engine specifications and components may be altered from the original model:

- 1) Cylinder head:
Intake and exhaust tracts surfaces may be polished. No addition of material is allowed.
The gasket is free and compression ratio can be modified.
- 2) Camshafts and camshaft sprockets are free.
Valve springs can be replaced but titanium springs are forbidden.
- 3) Pistons, pistons rings, pins and clips: may be altered or replaced from those fitted to the engine.
- 4) Exhaust system:
Exhaust pipes and silencers may be altered or replaced.
- 5) Clutch: An aftermarket or modified clutch is permitted.
- 6) Radiator and/or oil cooler may be altered or replaced, additional radiators and oil cooler may be added.
- 7) Oil pumps and oil liners may be altered or replaced. Oil lines containing positive pressure, if replaced, must be of metal reinforced construction with swaged or treaded connectors.
- 8) Oil tanks may be added or modified.
- 9) Air filter may be altered or replaced.
- 10) Fuel pump may be modified or replaced.
- 11) Ignition / Engine Control System (ECU), hardware and software may be modified or changed.
- 12) Generator, alternator, electric starter may be modified or replaced.

13) Secondary transmission is free.

During the event, an 'engine change' means removing the engine from the frame. Engine 'A' originally fitted in the frame of the bike can be removed from the frame to be repaired and be replaced by engine 'B' Engine 'A' may be repaired during the event on the condition that the engine crankcase(s) marked during the preliminary technical inspection remain(s) the same.

Repairs to the engine's 'top end' (cylinder + cylinder head) are free during the event. All intervention to the 'bottom-end' (inside the crankcases) will be considered as a change of engine.

A minimum of one bolt/nut used to fix the engine must be drilled in order to attach a seal embracing the frame.

The engine may be removed from the frame to repair a problem not related to the crankcase. This intervention may be done only after formal request and under the supervision of the Technical Steward. Only the Technical Steward can cut and replace the seals without the participant being penalised.

60.03 Chassis and ancillaries

Shock absorbers and associated springs are free.

The main chassis must be marked with the original Vehicle Identification Number (VIN). The frame number (VIN) must remain visible at all times.

The chassis shall not be replaced during the event. The frame may be repaired under the supervision of the Technical Steward.

The rear sub-frame can be modified, but the type of material must remain as in the production model and the weight cannot be lower.

Fairing and body can be modified or replaced.

Seat may be modified or replaced.

Battery may be changed but the nominal energy must be equal or higher than the original one.

Footrests and foot controls may be modified or replaced.

60.04 Weight

Minimum weight: 165 [kg]

01.64 SURVIVAL EQUIPMENT

In addition to the Equipment and Protective clothing (see Art. 01.65), it is compulsory to wear also during practice(s) and race(s). Please refer to FIM Bajas World Cup Regulations.

64.01 Camel bag

For the entire course, the wearing of a camel bag with the capacity of (at least) 2 litres of drinking water, is compulsory, under pain of disqualification.

01.65 EQUIPMENT AND PROTECTIVE CLOTHING DURING PRACTICE AND RACE

The FIM cannot be held liable for any injuries that a rider or passenger may sustain from the use of a specific item of equipment or protective clothing.

65.01 Clothing and protectors

It is compulsory that riders wear either a suit or trousers and long-sleeve shirt.

Repaired overalls are acceptable provided that the repair guarantees protection to the same standard as the original garment. The Chief Technical Steward has the right to refuse any temporary repairs which are not deemed to provide the same protection as the original garment.

Any modifications brought to the protectors remove the certification of the equipment and will not be accepted.

If the clothing and/or protectors listed below does not meet the technical requirements or is found to be defective, the Technical Steward must clearly mark in red (e.g. with a red dot) all international marks without destroying them and retain it until the end of the event. The rider must submit another clothing and/or protectors for approval by the Technical Steward. After an accident involving impact, the back and chest protector must be presented to the Technical Steward for examination.

65.01.1 Airbags

It is compulsory that riders wear an airbag eligible for competition. By eligible for competition it is to be understood: an airbag system (complete vest or gilet) inside which the chest and back protector are included. The current version of airbag system eligible for competition is available here: https://www.fim-moto.com/en/documents?tx_solr%5Bq%5D=airbag

65.01.2 Limb joints protectors

It is recommended that riders wear limb joint protectors for knees, hips, elbow and shoulders.

The limb joint protectors, if present, should be certified according the International norm:

- EN 1621-1, Level 1 or 2

65.01.3 Back protector

It is compulsory that riders wear a back protector.

The back protector must be certified according the International norm:

- EN 1621-2, Level 1 or 2, only CB (Central Back) or FB (Full Back)

Newer Labels (1621-2:2014)	
Full Back Level 1 or 2	<p>EN 1621 - 2: 2014</p>
Central Back Level 1 or 2	<p>EN 1621 - 2: 2014</p>
Older Labels (1621-2:2003)	
Full Back Level 1 or 2	<p>EN 1621 - 2</p>



65.01.4 Chest protector

It is compulsory that riders wear a chest protector.

The chest protector must be certified according the International norm:

- EN 1621-3, Level 1 or 2

CHEST PROTECTOR: must comply with EN1621-3.

<p>EN 1621-3 Level 1 or 2</p>	 <p>C TYPE A 1</p> <p>EN 1621 - 3</p>	 <p>C TYPE A 2</p> <p>EN 1621 - 3</p>
-----------------------------------	--	---

65.02 Footwear

Footwear, in a good condition, made of leather or other materials having equivalent properties, shall be worn and have a minimum height of 30 [cm].

65.03 Gloves

Riders shall wear gloves made of leather or other materials having equivalent properties.

65.04 Eye protection

Riders shall wear goggles (in case of an off-road helmet) or a full closed visor (in case of a full face circuit racing helmet). The use of glasses, helmet visors and "roll offs" is also permitted. The use of "tear offs" is forbidden for environmental reasons. The material used for glasses, goggles and visors must be made of shatter-proof material. Helmet visors must not be an integral part of the helmet.

Eye protectors which cause visual disturbance (e.g. scratched) must not be used.

01.67 WEARING OF HELMETS

- It is compulsory for all participants taking part in practice and races to wear a protective helmet. The helmet must be properly fastened, be of a good fit, and be in good condition. The helmet must have a chin strap type 'retention system'.
- A protective lower face cover must be present and must be not detachable and not moveable.
- Helmets constructed with an outer shell made of more than one piece are not permitted (e.g. they must not contain any seam).
- A retention system with a strap and the double D ring closing system is recommended.

- All helmets must be marked with one of the official international standard marks mentioned in Art. 01.70. Any FMN approval marks do not substitute the official international standard marks.
- A helmet is made to provide protection. A helmet is not a platform to attach foreign objects. Cameras or other accessories are NOT permitted nor shall be attached to the rider's helmet.
- Riders with long hair should tie it up in a bun, or braid and tuck it into their shirt or jacket.

Failure to observe the above rules will entail exclusion.

01.69 HELMET OPERATIVE INSTRUCTIONS

69.01

Scrutineers, under the supervision of the Chief Technical Steward, may check prior to practice and the races that all helmets meet the technical requirements.

69.02

If a helmet does not meet the technical requirements or is found to be defective, the Technical Steward must clearly mark in red (e.g. with a red dot) all international marks without destroying them and retain the helmet until the end of the event. The rider must submit another helmet for approval by the Technical Steward. After an accident involving impact, the helmet must be presented to the Technical Steward for examination.

69.03

All helmets must be intact and no alteration must have been made to their construction. After an accident involving a shock or impact, the helmet must be presented to the Technical Steward for examination.

69.04

The Chief Technical Steward and/or the Technical Steward may perform the following checks before the rider is permitted to take part in practice of the race:

69.04.1 That the helmet fits well on the rider's head.

69.04.2 That it is not possible to slip the retention system over the chin, when fully fastened.

69.04.3 That it is not possible to pull the helmet over the rider's head by pulling it from the back of the helmet.

01.70 RECOGNISED HELMET APPROVAL MARKS

Helmets must conform to one of the recognised international standards:

FIM	FRHPhe-02
EUROPE	ECE 22-05 or ECE 22-06 (only "P" type)
JAPAN	JIS T 8133:2015 (only "Type 2 Full face")
USA	SNELL M 2015 or SNELL M 2020D or SNELL M 2020R or SNELL 2025R or SNELL 2025D

Examples of labels are reported below:



~~As from 01/01/2024, FIM homologated helmets according to the FRHPhe-02 (with a valid FIM homologated label) are strongly recommended, and will be mandatory as from 01/01/2026. All the other standards will be forbidden.~~

A list of FIM Homologated helmets will be available on

https://d.frhph.org/p/public/Public_Circuit_Helmets_Homologated_Helmets_FRHPhe_02_Off_Road

01.75 BADGE OF THE FIM

Under certain circumstances the FIM may permit the use of the FIM badge on certain equipment in order to show that the latter conforms to the standards laid down by the FIM. When this authorisation is granted and provided the equipment on which it appears is in good condition, the badge is then the guarantee of the conformity with the standard set by the FIM.

01.76 NUMBER SASHES (BIBS)

The starting number on the rider's bib or vest must be the same as on his motorcycle.

Starting numbers must be in conformity with the following specifications:

76.01

Black numbers on a white background must be used.

76.02

The size of the area in which numbers are printed is: 25 x 25 [cm] maximum.

76.03

Height of number: 15 [cm].

76.04

Width of number: 6 [cm].

76.05

Width of stroke: 2 [cm].

76.06

Only the space outside the 25 x 25 [cm] area may be used for publicity.

76.07

Bibs manufactured from PLASTIC material are not allowed.

01.77 TECHNICAL VERIFICATIONS**77.01 Preparation**

- Prior to the Technical Verifications, it should be decided who is doing what and note decisions. "Efficiency" must be the watchword. Always keep cheerful and remember the reasons for scrutineering: SAFETY AND FAIRNESS.
- Before the START of the competition, a closed and guarded area (closed parc/parc-fermé) shall be prepared.
- Inspection must take place under cover with a large enough area.
- Inspection area must be supplied with the necessary equipment, including tables, chairs, electric light and power outlet.
- The necessary tools are listed below:
 - ✓ Revolution meter
 - ✓ Sound meter, calibrator and spare batteries
 - ✓ Slide calliper (for verifying engine capacity, carburettor diameter, etc.)
 - ✓ Depth gauge
 - ✓ Steel measuring tape
 - ✓ Arrangement for measuring ground clearance (for Sidecars)
 - ✓ Seals

- ✓ Weighing apparatus (to be furnished by the Organiser) (and set of reference weights)
 - ✓ Tools for measuring the engine capacity
 - ✓ Lampoil tester is recommended and when used, it indicates the cylinder capacity. When a more precise measurement is required, the Chief Technical Steward may ask to take the cylinder head off the cylinder.
 - ✓ Colour for marking parts
 - ✓ Heat resistant stickers or paint for marking the silencer (and solvent)
 - ✓ Magnet
 - ✓ Adequate fuel sample bottles
 - ✓ PC with CD Drive + updated operating system
 - ✓ Printer, etc. are recommended
 - ✓ Calculator
- The necessary documents are listed below:
 - ✓ Supplementary Regulations
 - ✓ FIM Technical Rules - current year
 - ✓ FIM Rules of the discipline concerned
 - ✓ FIM Sporting Code
 - ✓ Homologation papers (if applicable)
 - ✓ Writing material
 - ✓ Technical Verifications forms
 - All necessary measures and administrative equipment should be in place at least 1/2 hour before the start of the Technical Verifications is due to open (time in Supplementary Regulations).

77.02 Verifications

- The Technical Verifications must be carried out in conformity with the procedure and times fixed in the CEN Rules and the Supplementary Regulations of the event.
- The Sound control must be carried out first. The Sound level will be recorded in the technical card. The exhaust silencer will be marked with paint or sticker.
- An example of minimum verifications that shall be performed is given below:

INITIAL TECHNICAL VERIFICATIONS	BAJAS
Make + model	✓
Sound	✓
Cut-off switch	✓
Self-closing throttle	✓
Lights (front, rear, brake)	✓
Race fuel certificate	✓

Vehicle identification plate/chassis number	✓
Crankcase	□
Wheels (hubs)	□
Registration plate + insurance (green card)	✓
Fuel tank	✓
Silencer	✓
Guard for the countershaft sprocket and rear sprocket	✓
Handlebar ends + protection + levers	✓
Side stand	✓
Tyres	✓
Helmet(s) + national colors	✓
Protective clothing	✓

- An overall inspection of the motorcycle must be carried out in conformity with the FIM rules. On accepted motorcycles a sticker or paint will be applied on the front of the main frame, in conformity with Arts. 082.8.2.1 of the Bajas Appendices.
- The Technical Verifications will only be carried out when the Technical Verifications form of the motorcycle has been presented by the rider or his mechanic.
- The fuel tank shall contain a minimum amount of fuel for the sound control.
- At the arrival, at the end of the competition, all the marked parts on the motorcycles must be controlled. After control, the machines must be placed in a closed park for 30 minutes after arrival of the last rider from the class concerned, in case a protest is lodged or further examination is required.
- If a motorcycle or a part of a motorcycle has to be verified and completely dismantled, the motorcycle, the part or the group of parts must be sealed and shipped to a place where the required tools are present for a disassembly. The Clerk of the Course/FIM Race Director must take the decision for this operation.

The disassembly and the verification of the motorcycle or the parts in question must take place in the presence of the Technical Steward, appointed to the event.

The Organiser will pay the costs for the transportation and for the verification.

- If a disassembly is required and ordered by the Clerk of the Course/FIM Race Director, following a protest, the losing party will incur all the transportation and

verification costs, or a part of these costs fixed by the Clerk of the Course/FIM Race Director.

77.03 FMNR Chief Technical Steward and technical stewards

- The Chief Technical Steward must be in attendance at an event one hour before the Technical Verifications are due to begin. He must inform the Clerk of the Course/FIM Race Director and FIM Technical Director, if present, of his arrival.
- The Chief Technical Steward must ensure that all technical stewards appointed for the event carry out their duties in a proper manner. The Chief Technical Steward shall appoint the technical stewards to individual posts for the race, practices and final control.
- Scrutineers can have different tasks, but the team of scrutineers must have a minimum of four persons. The FMNR Chief Technical Steward must be a holder of an FIM SENIOR Technical Stewards Licence and at least one Technical Steward must hold a FIM Technical Stewards Licence. A minimum number of scrutineers is required according to the following:
 - Sound test, silencer marking: two
 - Machine inspection, helmet and clothing: twoIt is recommended to have 2 up to 4 helpers (staff).
- The Sound Control Officer (SCO) must be holder of a valid FIM Technical Steward's license, come with good knowledge and experience of the sound control and application of the test method. The FMNR may propose the services from a special technician (acoustic engineer) if there is no FIM licenced Technical Steward available to act as SCO.
- After the Technical Verifications has been completed the Chief Technical Steward will submit to the Clerk of the Course/FIM Race Direction a list stating the names of the accepted riders, machines and the sound levels.
- During the event, in the arrival and departure areas, the technical steward must control the repairs and changes made to the machines. He must control that no outside assistance is made. He must also control the condition of the machines.
- At individual time checks, the technical steward must control repairs and other technical assistance. He must also control that the machines are marked in order to ensure that no change in motorcycle occurred on the course.
- At the arrival, at the end of each day, the technical steward must check all parts and the condition of the machine. A rider is allowed an extra 30 minutes to repair or replace a silencer and/or exhaust pipe only.
- If a motorcycle is involved in an accident, the Technical Steward must check the machine to ensure that no defect of a serious nature has occurred. However, it is the responsibility of the rider to present his machine for this re-examination together with the helmet and clothing worn.

- The Chief Technical Steward has the right to look/ inspect any part of the motorcycle at any time of the event.
- All technical stewards shall be well informed and shall make sure their FMN has supplied them with all technical "updates" that may have been issued subsequent to the printing of the Technical Rules books.

77.04 FIM Technical Director

- The FIM Technical Director is appointed by the Director of the FIM International Technical Commission in consultation with the Director of the FIM Cross-Country Rallies Commission.
- The FIM Technical Director is not responsible for the technical verifications but will ensure that they are carried out in accordance with the FIM Technical Rules.
- The FIM Technical Director works in cooperation with the FIM Race Director and the FIM Delegate.
- The authority and duties of the FIM Technical Director include but are not limited to (Please, also refer to the FIM Technical Rules):
 - a) The FIM Technical Director will report any concerns or deficiencies relating to the technical verifications to the FIM Race Director and FIM Delegate and present proposals to resolve such concerns.
 - b) The FIM Technical Director is the final arbiter in relation to technical issues at the event.
 - c) The FIM Technical Director will examine with the Chief Technical Steward the motorcycle(s) and the protective equipment of any rider(s) involved in serious or fatal accidents and present a written report to the FIM Delegate.
 - d) The FIM Technical Director will attend all meetings of the Race Direction, but without voting rights.

77.05 Rider and/or mechanic

- The rider and/or the mechanic and/or the Team Manager must attend at least once the Technical Verifications with the (rider's) machine within the time limits stated in the Supplementary Regulations.
- On request of the technical steward, the rider must present themselves to the Technical Verifications.
- The maximum number of persons present at the technical verifications will be the rider and/or the mechanic and/or the Team Manager.
- A rider remains at all times responsible that his machine and his personal protective gear are in conformity with the FIM Bajas Technical Rules.

- The rider and/or the mechanic and/or the Team Manager must present a clean motorcycle in conformity to the FIM Bajas Technical Rules and a duly filled in and confirmed Technical Verification form.
- A rider and/or the mechanic and/or the Team Manager must present one motorcycle only.
- The rider and/or the mechanic and/or the Team Manager must present the rider's protective wear (equipment), e.g. helmet and clothing.
- Riders/mechanics/Team Managers must confirm their agreement by signing the register. The motorcycles will then be placed in a closed park.
- Competitors must retrieve their machines within 30 minutes after the opening of the closed park area, except for the machines that are chosen for disassembly. After this time limit, the closed park officials will no longer be responsible for the machines left behind.
- Any rider failing to report as required by the provisions below may be excluded from the meeting.
- The Clerk of the Course/FIM Race Director may prohibit any person who does not comply with the rules, or any rider who could be a danger to other participants or to spectators, from taking part in the competitions.

01.78 DANGEROUS MACHINES

If, during practice or the race, a Technical Steward finds that a machine is defective and might constitute a danger to other riders, he must immediately notify the Clerk of the Course/FIM Race Director or his deputy. It is their duty to exclude such a machine either from the practice or from the race itself.

01.79 SOUND CONTROL

Exhaust pipes and silencers must fulfil all the requirements concerning sound control (see also FIM Sound Regulation). Please refer to:

https://www.fim-moto.com/en/documents?tx_solr%5Bq%5D=sound

01.80 FUEL REGULATIONS

Please refer to FIM Fuel Regulations:

https://www.fim-moto.com/en/documents?tx_solr%5Bq%5D=fuel

Technical Rules SSV's

Règlement Technique SSV

Table of contents

01.80	DEFINITION.....	40
01.81	REQUIREMENTS	40
01.82	FUEL TANK	40
01.83	CHASSIS	42
01.84	SAFETY CAGE.....	42
01.85	SEATS	43
01.86	SEAT HARNESSSES.....	43
01.87	BODYPANEL	46
01.88	INTERIOR.....	47
01.89	TRANSMISSION.....	47
01.90	MINIMUM WEIGHT.....	49
01.91	ENGINE	49
01.92	ELECTRICAL EQUIPMENT	52
01.93	SUSPENSION.....	53
01.94	WHEELS	54
01.95	BRAKING SYSTEM	56
01.96	STEERING.....	56
01.97	FIRE EXTINGUISHERS.....	57
01.98	LIGHTS	59
01.99	DRIVER AND CO-DRIVER EQUIPMENT.....	59

01.80 DEFINITION

SSV (Side-by-Side Vehicle) are motor vehicles propelled by a single thermal engine, four wheels, two- or four-wheel driven (designated 4X2 or 4X4), produced in series, (minimum 100 units), equipped with a steering system and a steering wheel, controlled by the rider. The seat of the driver and the passenger are positioned 'side-by- side'.

SSV's must be originally designed for 1-, 2- or 4- passengers and fitted with all the equipment required in the international convention on public road circulation. These vehicles must have a circulation insurance and a registration plate approved by the local Institute of Mobility and Transport (IMT) as a quadricycle, T1, T2, T3, or equivalent entity in the case of vehicles registered abroad.

Original part(s): A part which has undergone all the stages of production foreseen and carried out by the manufacturer of the vehicle concerned, and originally fitted on the production vehicle.

01.81 REQUIREMENTS

81.01 Fuel tanks

Any tank containing oil or fuel must be situated in the main structure of the vehicle (position of the fuel tank: see article 82.05).

If the OEM fuel tank is kept, no changes are necessary. If an additional tank is mounted that tank must comply with these regulations.

81.02 Materials

Unless explicitly authorised by the present regulations, the use of the following materials is prohibited unless it corresponds exactly to the material used in the same components of the production vehicle:

- Titanium alloy
- Magnesium alloy
- Ceramics
- Composite

81.03 Registration plate

The original registration plate must be securely fitted to the rear of the vehicle. It must always be visible and with its own lighting. The sharp edges must be covered to prevent injuries.

81.04 Screws, nuts and bolts

Unless otherwise stated, all threaded fasteners must be manufactured from iron-based alloys or aluminium-based alloys.

81.05 Maximum speed

130 km/h

01.82 FUEL TANK

The fuel tank must be the original of the vehicle or homologated according to an International Standard for Motorsport Safety.

82.01 Number of fuel tanks

Maximum number of fuel tanks: 2

82.02 Fuel tanks capacity

Maximum combined capacity of the fuel tanks is 130 litres

82.03 Fuel tanks shielding

All vehicles must have shielding (6 [mm]. minimum thickness for aluminium alloy plate or 3 [mm]. minimum thickness for steel plate) fitted directly onto the chassis underneath any part of the tank(s) situated less than 200 [mm] above the plane defined by the lower face of the lowest tubes of the chassis that are situated within the vertical projection of the fuel tank(s).

82.04 Fuel tanks housing

The soft tanks must be contained in a leak-proof housing securely attached to the chassis/safety cage, the minimum specifications of which are as follows:

- Sandwich construction "Glass Reinforced Plastic + Kevlar or Carbon + Kevlar with an intermediate layer of absorbent material" with a minimum wall thickness of 10 [mm]
- Aluminium alloy with a minimum wall thickness of 3 [mm] except for the areas for mounting to the chassis.

A leak-proof cover, made from non-flammable material, easily accessible and removable only with the use of tools, must be installed in the protection for tanks, in order to allow the checking of the validity expiry date.

No part of this housing may be situated less than 40 [mm] above the lower face of the lowest tubes of the chassis that are situated within the vertical projection of the fuel tank.

The housing must not be:

- Longitudinally less than 800 [mm] rearward of the front axle centreline,
- Transversally less than 50 [mm] (inwards) from the outer part of the main rollbar feet
- Vertically less than 200 [mm] from any point of the upper part of the main rollbar.

82.05 Fuel tanks position

Parts ahead of the back of the seats must be situated below the mounting points of the seats to the chassis.

Any fuel tank must be situated inside the main structure of the vehicle.

If the OEM fuel tank is maintained, its original location must be kept.

82.06 Fuel tanks filler hole

The fuel tank filler hole must be situated outside the cockpit.

82.07 Fuel tanks outlet

The outlet of the fuel tank breather and hose must be kept away from hot areas. A safety valve must be installed (and remain visible during all the technical scrutineering procedure(s); it must close automatically by gravity in case of a rollover.

The breather hose should be raised to near the upper limit of the chassis and again directed downwards.

82.08 Fuel lines

Fuel hoses must be resistant to fuel and must have a minimum burst pressure of 10 bars at the minimum operating temperature of 80°C.

All fuel lines which feed (or return from) the engine are recommended to be equipped with automatic fuel shut-off valves, positioned directly next to the fuel tank and shall automatically close all pipelines under pressure in the event of a rupture or loss.

82.09 Fuel cooling

The fitting of fuel coolers is authorised on the return circuit to the tank.

01.83 CHASSIS

83.01 Chassis

Only tubular chassis in iron-based alloys are authorised.

83.02 Standard components

The position of the following components must remain unchanged (unless otherwise specified) in relation to the standard vehicle:

- Mounting points of the suspension and shock absorber components
- Engine and its supports
- Transmission parts (gearbox / differentials ...)
- Steering rack
- Pedal box (see article 5.14)

All these components must be interchangeable (without modification) with those of the standard vehicle.

01.84 SAFETY CAGE

The fitting of a safety cage is compulsory. The safety cage must be homologated according to an International Standard for Motorsport Safety with an homologation paper and/or identification plate. The safety cage must comply with FIM OFF-ROAD ADDITIONAL TECHNICAL REGULATION.

84.01 Around safety cage

Inside the cockpit, the passage of the following elements between the side members of the body panel and the safety cage are forbidden:

- Electric cables
- Lines carrying fluids (except for drinking water and windscreen washer fluid)
- Lines of the fire extinguishing system.

Members may enter into the occupant's space by passing over the dashboard and trimming.

84.02 Safety cage protect padding (move A1.10)

All tubes of the cage identified on Figure 3 and all roof reinforcements must be fitted with paddings approved for competition. Each padding must be fixed in such a way that it is not moveable from the tube and must be located everywhere the helmet can touch the cage.

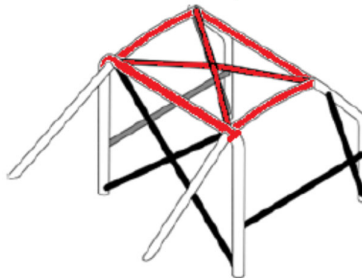

Figure 3

84.06 Driver/Co-driver back protection

The occupants' seats must be shielded by a protective panel, positioned directly behind the driver and passenger's seats. The protective panel must be rigidly fixed by welding or by bolts to the main roll-bar of the safety cage. This protective panel must withstand fire, made from steel or an aluminium alloy (minimum thickness 2 [mm]). This portion must cover the whole height and the whole width of the safety cage. Holes are permitted only to put safety equipment's (harnesses).

01.85 SEATS

All the occupants' seats must be homologated according to an International Standard for Motorsport Safety.

85.01 Seat attachments

Each seat must be attached to the chassis via at least 4 supports, 2 at the front and 2 at the rear of the seat.

Supports must be attached to the seat and the chassis using bolts with a minimum diameter of 8 [mm] (quality 8.8 or higher) and counter plates. The seats must have reinforcement at the locations of the fixation.

The minimum thickness of the supports and counter plates is 3 [mm] for steel and 5 [mm] for light alloy materials. The minimum longitudinal dimension of each support is 6 [cm].

The minimum area of contact between support, shell/chassis and counter plate is 40 [cm²] for each mounting point.

Each mounting point must be capable of withstanding a force of 15000 [N] applied in any direction. If quick release systems are used, they must be capable of withstanding vertical and horizontal forces of 18'000 [N], applied non-simultaneously.

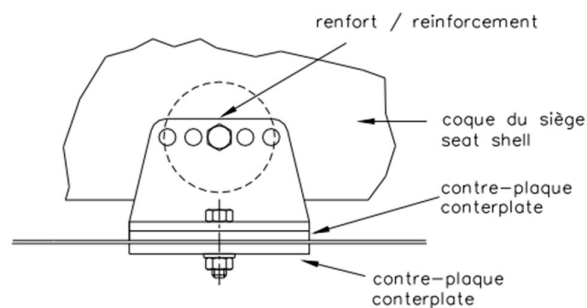

253-65

01.86 SEAT HARNESSSES

It is compulsory to use seat harnesses homologated according to an International Standard for Motorsport Safety for each occupant.

It is not allowed to mix parts of harnesses. Only complete sets, of proprietary manufacture, may be used.

The harnesses must be replaced after every severe collision, and whenever the webbing is cut, frayed or weakened due to the actions of chemicals or sunlight.

Elastic devices attached to the shoulder straps are forbidden.

Any harness which does not function perfectly must be replaced.

A safety harness must be used in its homologation configuration without any modifications or removal of parts, and in conformity with the manufacturer's instructions.

86.01 Seat harnesses anchored points

It is prohibited for the safety harnesses to be anchored to the seats or their supports. The anchorage points of the series vehicle can be used.

If the installation on the series anchorage points is impossible, new anchorage points must be installed on the chassis, a separate one for each strap the furthest rearward as possible for the shoulder straps.

Care must be taken that the straps cannot be damaged through chafing against sharp edges.

The recommended geometrical locations of the anchorage points are shown in Drawing below.

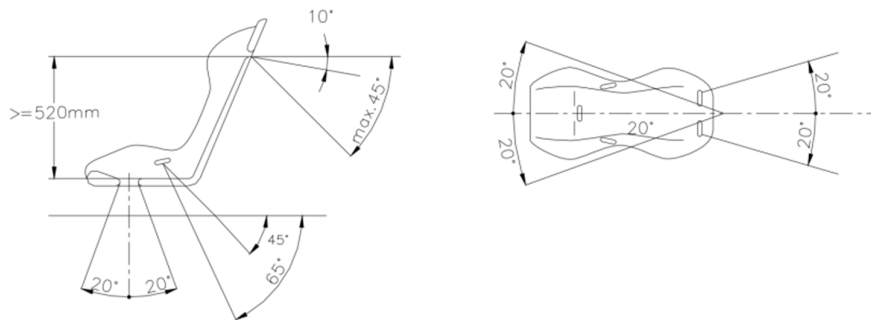

Figure 4

In the downwards direction, the shoulder straps must be directed towards the rear, and must be installed in such a way that they do not make an angle of more than 45° to the horizontal from the upper rim of the backrest, although it is recommended that this angle does not exceed 10°.

The maximum angles in relation to the centreline of the seat are 20° divergent or convergent (measurement in horizontal projection).

Anchorage points creating a higher angle to the horizontal must not be used.

If mounting on the series anchorages is impossible, the shoulder straps may be fixed or leaning on a rear transverse tube fixed to the cage or to the top anchorage points of the front belts.

The shoulder straps may also be fixed to the safety cage or to a reinforcement bar by means of a loop, and may also be fixed to the top anchorage points of the rear belts, or be fixed or leaning on a transverse reinforcement welded between the backstays of the cage (see Figure 5) or on transverse tubular reinforcements.

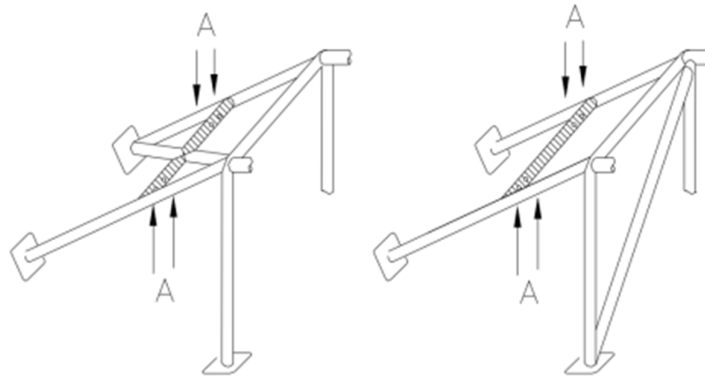

Figure 5 : Mounting holes for harnesses

In this case, the use of a transverse reinforcement is subject to the following conditions:

- The transverse reinforcement must be a tube measuring at least 38 [mm] x 2.5 [mm] or 40 [mm] x 2 [mm], made from cold drawn seamless carbon steel, with a minimum tensile strength of 350 [N/mm²]
- The height of this reinforcement must be such that the shoulder straps, towards the rear, are directed downwards with an angle of between 10° and 45° to the horizontal from the rim of the backrest, an angle of 10° being recommended.
- The lap and crotch straps must not pass over the sides of the seat but through the seat, in order to wrap and hold the pelvic region over the greatest possible surface.
- The lap straps must fit tightly in the bend between the pelvic crest and the upper thigh. Under no conditions must they be worn over the region of the abdomen
- The straps may be attached by looping or by screws, but in the latter case an insert must be welded for each mounting point.

These inserts must be positioned in the reinforcement tube and the straps must be attached to them using bolts of M12 8.8 (ISO standard, minimum) or 7/16 UNF specification.

Each anchorage point must be able to withstand a load of 1470 [daN], or 720 [daN] for the crotch straps.

In the case of one anchorage point for two straps (prohibited for shoulder straps), the load considered must be equal to the sum of the required loads.

For each new anchorage point created, a steel reinforcement plate with a surface area of at least 40 [cm²] and a thickness of at least 3 [mm] must be used.

The effectiveness and longevity of safety harnesses are directly related to the manner in which they are installed, used and maintained.

They must also be replaced if metal parts or buckles are bent, deformed or rusted.

86.02 Seat harnesses release

Two belt cutters must always be carried on board (identified with a sign). They must be easily accessible for the driver and co-driver when seated with their harnesses fastened.

Furthermore, it is recommended that for competitions which include public road sections, the harnesses be equipped with push-button release systems.

01.87 BODYPANEL

The vehicle must be fitted with its original body panel. The only modification allowed are the one requested by this regulation, when safety items are added for example.

A protective shield, installed on the top of the safety cage is compulsory, minimum thickness shall be of minimum 2 [mm] if it is made of steel or aluminium alloy.

A protective panel must be installed in front of the occupants' feet, on both sides of the SSV. This protection panel must be made of steel or aluminium with a minimum thickness of 2 [mm]. This panel must be attached to the chassis' tubes of the chassis

All parts of the body panel must be carefully and fully finished, with no temporary or makeshift parts and no sharp edges.

No mechanical component may be visible from above with the exception of shock absorbers, suspension arms, transversal driveshaft's, radiators, fans, wheels and spare wheels, including their anchorage points and attachments.

All parts having an aerodynamic influence and all parts of the body panel must be secured rigid to the completely sprung part of the vehicle (chassis/body unit); they must not have any degree of freedom, must be securely fixed and must remain immobile in relation to this part when the vehicle is in motion, with exception of the driver's and/or co-driver's ventilation sliders / scoops.

87.01 Exterior

The maximum overall length is 3550 [mm] without spare wheels.

The maximum width the vehicle with of the body panel is 1900 [mm] without rear view mirrors and/or spare wheels.

A windscreen is optional. If a windscreen is installed, it must be made of non-breakable, shatterproof materials.

87.02 Lateral windows

Free, but it must be possible to remove the front doors or the windows of the front doors from inside the cockpit without the use of tools.

87.03 Windscreen wipers, motor and mechanism

These items are free.

87.04 Rear view mirrors

The vehicle must be fitted with two rear view mirrors, one on each side of the car, to provide efficient views to the rear. Each mirror must have a minimum area of 90 [cm²].

87.05 Rear camera

One rear view camera is permitted provided if it is non-swivelling.

87.06 Aerodynamic device

Identical to the standard vehicle /no modification authorised.

87.07 Underbody protections

The fitting of underbody protections is authorised on the following conditions:

- They must respect the ground clearance

- They must be removable
- They must protect only the following parts: engine, radiator, intercooler, gearbox, centre differential, rear differential, driveshaft's (longitudinal and transversal), subchassis, suspension parts, steering and exhaust line.

01.88 INTERIOR

88.01 Interior safety

The cockpit must be designed to ensure the comfort and safety of driver and possible co-drivers. No part may present sharp edges or points.

No mechanical part may protrude into the interior of the cockpit. Any equipment that could involve a risk must be protected or insulated and must not be situated in the cockpit.

The cars must have lateral openings allowing the exit of the driver / co-driver.

88.02 Inspection hatches

Inspection hatches are authorised in the bulkheads of the cockpit.

88.03 Bulkhead

A leakproof and flameproof bulkhead made of steel or aluminium alloy (minimum thickness 2 [mm]) or in composite material (minimum thickness 5 [mm]) is compulsory behind the seats and must be fully in contact with the main rollbar of the safety cage.

88.04 Protection nets

Vehicles without side windows must be fitted with lateral protection nets attached to the main rollbar and doors using a quick release system or an articulated window rim. The use of "clip" fixings is recommended. The fixings of the net must not be removable without the use of tools.

These nets must have the following characteristics:

- Minimum width of the strips: 19 [mm]
- Minimum size of the meshes: 25 x 25 [mm]
- Maximum size of the meshes: 60 x 60 [mm]

The lateral opening circumscribed by the tubes of the lateral roll bar and the door upper side must be completely closed by the protection nets.

01.89 TRANSMISSION

The complete transmission (except otherwise specified) of the standard vehicle must be kept without modification.

A modification is only allowed, in order to de-activate the active systems if necessary.

All the parts must be available, as spare parts, through the Manufacturer's commercial network.

89.01 Transmission shaft

Transmission shafts are free but must be made of steel. In addition, they must be solid and in one piece and the joints must come from a series vehicle.

The transmission shaft location must be identical to the standard vehicle and must respect the following conditions:

- It may be situated inside or outside the cockpit.
- The floor of the cockpit must be closed with a metallic sheet, minimum thickness 1.5 [mm].
- The metallic sheet must be securely fixed to the chassis.

89.02 The transmission tunnel

The installation of a transmission tunnel is mandatory if the transmission shaft is located inside the cockpit and can be modified with the following conditions:

- It must enclose the longitudinal shaft over the complete length of the cockpit.
- It must be made from a steel sheet of minimum thickness 1.5 [mm], or from a steel tube of minimum thickness 3.0 [mm].
- The transmission tunnel must be securely fixed to the floor or the chassis in such a way as to ensure that it cannot be detached during normal use or in case of an accident.
- The entire surface of the transmission tunnel must be free of any kind of hole, with the exception of the part attaching it to the floor or chassis.

If fitted outside the cockpit, a minimum of two steel safety straps, of minimum thickness 3.0 [mm] and minimum length 250 [mm], must be fitted to each longitudinal shaft to prevent it from hitting the ground in case of breakage.

Should any fuel or oil tank be close to a longitudinal shaft, it is compulsory that the tank has extra protection in the walls close to the shaft.

89.03 Pedal box

Identical to the standard vehicle but the axis of the pedal box must be situated behind or directly above the axis of the front wheels.

89.04 Gearbox

Modification authorised on the gearbox / differential housing is allowed only to install an additional lubrication system.

89.04.01 CVT system

Identical to the standard vehicle / no modification authorised.

The belt is free provided that it is available as a spare part (reinforced or not) through the Manufacturer's commercial network.

A system for cooling the belt by air is authorised.

89.04.02 Manual or semi automatic or automatic operation control

Identical to the standard vehicle / no modification authorised.

89.04.03 Gearshift control

Gear shift type is free.

The gear shift lever must be fixed on the floor or on the steering column and can be adjustable. If fixed on the steering column the link between the gear lever and the gearbox must not be by cable or electric wires in case of semi-automatic or automatic control.

89.04.04 Cut-off sensor for gear command

Identical to the standard vehicle / no modification authorised.

89.04.05 Lubrication

An additional lubrication and oil cooling device is allowed (circulation pump, radiator and air intakes)

89.04.06 Clutch

Free, but principle and diameter must remain identical to the standard vehicle / no modification authorised.

89.04.07 Control system

Hydraulic or mechanic or other. Identical to the standard vehicle / no modification authorised.

The clutch stop (clutch release bearing) is free.

89.04.08 Master-cylinder and tank

Master cylinder and hydraulic oil reservoir are free.

89.04.09 Supports for Gearbox / CVT / Differentials

Supports are free.

01.90 MINIMUM WEIGHT

No Minimum weight

01.91 ENGINE

The maximum cylinder capacity is set at 1050 [cm³] for normally aspirated engines and for supercharged engines. The engine of the standard vehicle must be kept as original without modifications.

91.01 Positions and inclination of the engine

Identical to the standard vehicle / no modification authorised.

91.02 Engine supports

Supports are free.

91.03 Plastic shields

Engine shields made of plastic material, the purpose of which is to hide mechanical components in the engine compartment, may be removed if they have a solely aesthetic function.

91.04 Screws, nuts and bolts

A nickel-based alloy may be used for the fixing of the exhaust manifold to the cylinder head.

91.05 Gaskets

All gaskets are free.

91.06 Cylinder head gasket

Identical to the standard vehicle / no modification authorised.

91.07 Ignition

The make and type of the spark plugs and leads are free.

The use of ceramics for spark plugs is authorised.

91.08 Fuel injection system

91.08.01 Fuel rail

Free.

91.08.02 Injectors

Identical to the standard vehicle / no modification authorised.

91.08.03 Electronic control unit (ECU) and engine control software

The ECU is free but the electronic control unit must come from a large scale production catalogue or from a competition parts catalogue.

91.08.04 Sensors

Sensors shall be identical to the standard vehicle / no modification authorised.

91.08.05 Actuators

Identical to the standard vehicle / no modification authorised.

91.09 Air intake system**91.09.01 Air filter**

The choice of air filter element and its position is free. The plenum chamber and the lines between the restrictor / manifold and the atmosphere are free. Engine intake air must not be taken from inside the cockpit and any modifications must not affect the structure of the vehicle.

91.10 Supercharging system

Identical to the standard vehicle (as homologated for public road).

91.11 Pressure regulation valve (waste gate) / System for injecting air into the exhaust manifold

These parts must remain identical as fitted on to the standard vehicle / no modifications authorised.

91.12 Exhaust line

The silencer(s) exit(s) must be horizontal and situated within the perimeter of the vehicle defined by the chassis, body panels, roll cage and mud flap brackets.

The exits of the exhaust system must be visible from outside.

The extremity of the silencer(s) must not pass the vertical tangent of the rear tyres.

The edges of the silencer(s) shall be rounded (straight, sharp cuts are not permitted).

All the exhaust gases (with the exception of the gasses coming from the wastegate) must pass through the silencer(s). Exhaust fumes must be discharged towards the rear but not in such a manner as to raise dust, foul the tyres or brakes.

Only the original (standard) installed exhaust valve systems provided by the manufacturer is authorised.

91.13 Heat shielding of the exhaust system

Heat shielding elements on the exhaust system or on components in close proximity to the exhaust system are authorised, but must be removable.

91.14 Cooling system

The original water pump must be retained.

91.15 Coolant radiator

The position of the coolant radiator is free but forbidden in the cockpit. The fans and their position are free, as are their electric looms.

Hot air shall be directed away from the driver/passenger's compartment.

91.16 Coolant lines

The expansion chambers are free, provided that the capacity of the new chambers does not exceed 2 litres and that they are not located in the cockpit.

The liquid cooling lines external to the engine block and their accessories are free.

91.17 Lubrication system

Radiator, oil/water exchanger, lines, thermostat, filter and pump strainers are free.

Oil pressure may be increased by changing the discharge valve spring.

If the lubrication system includes an open type sump breather, it must be equipped in such a way that the oil flows into a catch tank (minimum capacity: 1 [litre]).

The fitting of one or several ventilators for cooling the engine oil is authorised, provided that this does not have any aerodynamic effect.

91.18 Oil sump

Identical to the standard vehicle / no modification authorised.

91.19 Exchanger (intercooler) of the supercharging system**91.19.01 Intercooler**

Identical to the standard vehicle / no modification authorised.

91.19.02 Supports and position of the heat exchanger

Support brackets and their position are free but are forbidden to be placed inside the cockpit.

91.19.03 Fans for cooling the exchanger

Identical to the standard vehicle / no modification authorised.

91.19.04 Cooling air ducts of the exchanger

Cooling air ducts are free.

91.19.05 Piping

All pipes between the supercharging device, the intercooler and the manifold are free (on condition that they remain within the engine bay), but their only function must be to channel air and to join various parts together.

91.19.06 Accessories

Except for the components mentioned in Art. 91.17 Lubrication System, the following accessories must derive from a homologated vehicle engine or from a commercial catalogue and be available for sale to the public:

- alternator
- air conditioning compressor
- air compressors

- fuel pumps
- hydraulic pumps

The number and position of these accessories are free provided that they remain within the engine compartment and/or within the main structure of the vehicle. They may not be placed within the cockpit area. Their method of operation drive systems is free.

Local machining and/or welding of an accessory is permitted for its fitting and/or function.

01.92 ELECTRICAL EQUIPMENT

92.01 Wiring loom & Fuses

All wiring loom (using appropriate size and diameter) and fuses are free.

92.02 Circuit breakers

Circuit breakers may be freely changed regarding their use, position, or number in the case of additional accessories. The general circuit breaker must be a spark-proof model and must cut all electrical circuits, battery, alternator or dynamo, lights, horns, ignition, electrical controls, etc. and must also stop the engine.

At least two circuit breakers must be installed:

- One inside the cockpit: It must be accessible from inside the vehicle by the driver and the co-driver seated and secured by their safety harnesses
- One outside the cockpit.

92.03 Battery

92.03.01 Number

Identical to the standard vehicle / no modification authorised.

92.03.01 Type

The make, capacity and cables of the battery are free. The nominal voltage must be the same or lower than that of the standard vehicle. The minimum weight of the battery is 3 [kg].

92.03.01 Location

The location of the battery(ies) is free, but the battery must be of the dry type if it is in the cockpit.

92.03.01 Fixation

Each battery must be securely fixed and the positive terminal must be protected.

Should the battery be moved from its original position, it must be attached to the body using a metal seat and two metal clamps with an insulating covering, fixed by bolts and nuts.

For attaching these clamps, metallic bolts with a diameter of at least 10 [mm] must be used, and under each bolt, a counter plate at least 3 [mm] thick and with a surface of at least 20 [cm²] beneath the metal of the body panel.

Wet batteries can be used, but must be placed and covered in a leakproof box, attached independently of the battery. The box must be attached independently to the chassis. The securing system must be able to withstand a deceleration of 25 [g].

92.04 Starter

92.04.01 Location

Identical to the standard vehicle / no modification authorised.

92.04.02 Make and type

Identical to the standard vehicle / no modification authorised.

92.05 Data acquisition system

A competitor data recording system is authorised, but only the following sensors are allowed:

- sensors fitted on the reference vehicle
- 3 temperature sensors (engine oil, engine water, gearbox or CVT)
- pressure sensors (1 oil and 1 fuel)
- 1 engine knocking sensor (only if fitted on standard engine)
- 1 fuel level gauge for each fuel tank
- any sensors necessary for the navigation system allowed by the supplementary regulations of the competition
- wheel speed sensors (maximum 2), only on driven wheels.

92.06 Sensors

Any radar system, vehicle speed measurement system (except pulse ring on the gearbox), gyroscope, load sensor (except sensor for engine ignition and/or injection cut-off) or restraining gauge is forbidden.

Accelerometers are authorised for data logging only on condition they are built into the dash display equipment.

92.07 Transmission of data

The transmission of data by WI-FI, radio and/or telemetry is prohibited.

01.93 SUSPENSION

93.01 Suspension type

It is forbidden to use active suspension (any system which allows control of flexibility, damping, height and/or attitude of the suspension when the vehicle is in motion).

93.02 Wishbones/suspension arms

Suspension triangle arms are free, but must remain interchangeable with those of the standard vehicle and must be manufactured in steel. No modifications to their respective mounting points on the chassis are permitted.

93.03 Joints (wishbones/links and suspension parts)

Rubber, ball joint, plain bearing, bearings (ball, roller, needle) : free

93.04 Hubcarriers/wheel bearings/wheel hubs

Identical to the standard vehicle / no modification authorised.

93.05 Connection the hubcarrier and the wishbone

Identical to the standard vehicle / no modification authorised.

93.06 Springs and shock absorbers

Only one shock absorber per wheel is authorised. Shock absorbers are free but their mounting points to the chassis must remain identical as on the reference vehicle.

Any adjustment of the springs and/or shock absorbers from the cockpit is forbidden. Adjustment is only possible when the vehicle is not in motion and only with the use of hand tools. The adjustment device must be situated on the shock absorber or its gas reserve.

Any connections between dampers are forbidden, the only connections permitted are the shock absorber fixing points passing through the chassis; these must have no other function.

93.07 Springs

A coil spring may be replaced with two or more springs of the same type, concentric or in series, provided that they can be fitted without any modifications other than those specified in this article.

93.08 Antiroll bars / fixings

Free, but only one antiroll bar per axle is permitted.

The adjustment of the antiroll bars from the cockpit is forbidden.

The antiroll bar systems must be exclusively mechanical, with no activation or deactivation possible.

Any connections between front and rear antiroll bars are forbidden.

01.94 WHEELS

The fitting of air extractors on the wheels is prohibited.

94.01 Rims

The diameter of the wheel rim is set at a maximum of 15["].

The rims and bead lock devices must be made of steel or aluminium alloy.

Wheel trims are forbidden

94.02 Tyres

The tires must be off-road type with a maximum diameter of 770 [mm] (complete wheel) measured at 1,2 [bar] and dismantled from the vehicle.

The use of tyres intended for motorcycles is forbidden.

The fitting of intermediate parts between the rims and the tyres is forbidden. The use of tyre balls or tyre blocks is forbidden.

Only one air valve is allowed per wheel and it must be fixed to the rim by a single hole, which has a maximum diameter of 12 [mm] and is positioned on the outer face of the rim.

Modifying the tyre is not authorised. It is forbidden to treat tyres with chemicals, cut or groove them, use tyre warmers or any other means which may alter the shape, minimum Shore hardness, construction or other characteristics.

Only tyres normally available from commercial or retail sources are authorised. The tyres shall appear on the tyre manufacturers range catalogue and tyre specification lists available to the general public.

The E approval mark and number as defined by the UN Vehicle Regulation R75 must be present on both the front and rear tyres sidewalls. The DOT approval mark is also accepted.

The maximum gap between two adjacent tread blocks in any plane perpendicular or parallel to the tread is 15 [mm].

The maximum height for the tread blocks is 15 [mm].

These measures do not apply to a width of 30 [mm] from the sidewalls and on each side. Tread blocks shall not protrude directly from the sidewalls of the tyre.

94.03 Fixation

A bolted "Beadlock" device is allowed.

Central nut wheel fixing is forbidden.

Wheel fixations by bolts may be freely changed to fixations by pins and nuts.

The wheels do not have to be of the same diameter.

Hub and nut protections are permitted.

94.04 System for inflating / deflating the tyres

The use of any system for inflating / deflating the tyres when the vehicle is in motion is forbidden. The inflating / deflating operation must only be carried out while the vehicle is not in motion.

The only system authorised is a system connected to the wheels through a flexible tube during the operation and connected to one valve per wheel.

In order to adjust the tyre pressure, any air going in or out must pass through a conventional complete and unmodified VG5 type valve coming from a series light utility vehicle.

The tube and its inflating manometer may be situated in the cockpit on condition that the operating pressure is lower than 10 bars.

The system may be fed by a 12V electric compressor and/or by compressed air bottles.

94.04.01 Compressed bottles

If the system to inflate the tyres is composed by compressed air bottles it must follow these restrictions:

- Maximum capacity [3 litres] each
- The mountings must be able to withstand a deceleration of 25 [g]
- Must not be situated in the cockpit.
- Must be positioned transversally in the vehicle
- Secured by at least two metal strap each

94.05 Spare wheel

The vehicle must be fitted with minimum one, maximum 2 spare wheel, free positions.

01.95 BRAKING SYSTEM

95.01 Control system

The pedal must normally control all the wheels and it is activated and controlled only by the driver. It includes at least two independent circuits operated by the same pedal (between the brake pedal and the callipers, the two circuits must be separately identifiable, without any interconnection other than the mechanical braking force balancing device).

The pressure is identical on the wheels of the same axle, with the exception of the pressure generated by the handbrake.

95.02 Brake disks

All the wheels must have a brake disk. The discs must come from a series vehicle or from a catalogue of competition parts. Their maximum diameter is set at 290 [mm].

95.03 Callipers

The callipers must come from a series vehicle or from a catalogue of competition parts with a maximum of 4 pistons.

Mounting spacers for brake callipers is free

95.04 Master-cylinders and tanks

Free

95.05 Proportional valve

Free

95.06 Pedal box

Original / No modification allowed

95.07 Handbrake

Free.

If the original vehicle is fitted with a handbrake, the function must be kept.

01.96 STEERING

96.01 General

The link between the driver and the wheels must be mechanical and continuous.

4-wheel steering is prohibited.

96.02 Steering wheel

The steering wheel may be removable from the steering column through a quick release mechanism. This mechanism must consist of a flange concentric to the steering wheel axis, coloured yellow and installed on the steering column behind the steering wheel.

The release must be operated by pulling the flange along the steering wheel axis. Push buttons and switches may be fitted.

Padding in the form of 60-240 [g/m²] material, with a minimum thickness of 40 [mm], must be fitted on the steering wheel over a minimum surface of 20 000 [mm²] (200 [cm²]) to protect the driver's face.

96.03 Steering mechanism

Identical to the standard vehicle / no modification authorised.

96.04 Steering mechanism position

Identical to the standard vehicle / no modification authorised.

96.05 Steering rods / Steering joints

Free but must be interchangeable (without modification) with those of the standard vehicle.

96.06 Steering column

Free but if the reference vehicle is must be fitted with an unmodified OEM (Original Equipment Manufacturer) energy absorbing device, it must be kept (without modification).

The locking system of the anti-theft steering lock must be rendered inoperative.

96.07 Support / steering column

Free.

96.08 Power steering

Identical to the standard vehicle / no modification authorised.

96.08.01 Oil cooling

Oil radiators, as well as a system for circulating the oil without generating pressure, are authorised.

96.08.02 Oil tank

Free.

01.97 FIRE EXTINGUISHERS**97.01 General**

All vehicles must be fitted with one or two manual fire extinguishers. It must be possible to activate the fire extinguishers by the occupants or by fire/rescue services

The following information must be visible on each extinguisher:

- Capacity
- Type of fire extinguisher
- Weight or volume of the fire extinguisher
- Date the fire extinguisher was checked, which must be no more than two years after either the date of filling or the date of the last check, or corresponding expiry date.

97.02 Permitted fire extinguisher

AFFF, FX G-TEC, Viro3, powder or any other fire extinguisher homologated.

97.03 Minimum quantity

- AFFF 2.4 [litres]
- FX G-TEC 2.0 [kg]
- Viro3 2.0 [kg]
- Zero 360 2.0 [kg]
- Powder 2.0 [kg]

97.04 Pressure

All extinguishers must be pressurised according in accordance with the manufacturer's instructions except for powder extinguishers with a pressure of 8 [bar] minimum and 13.5 [bar] maximum.

Furthermore, each extinguisher when filled with AFFF must be equipped with a mean of checking the pressure of the contents.

97.05 Location

At least one of the extinguishers must be easily accessible for the driver and the co-driver(s), seated normally with safety harnesses fastened and steering wheel in place.

All extinguishers must be adequately protected. The container may also be situated in the luggage compartment on condition that it is at least 300 [mm] from the outer edges of the bodypanel in all horizontal directions.

97.06 Fixation

It must be secured by a minimum of 2 screw-locked metallic straps and the securing system must be able to withstand a deceleration of 25 [g].

Furthermore, only quick-release metal fastenings, with metal straps, are accepted. The material of the securing system must operate within the -15°C to +80°C temperature range.

97.07 Pipes

Plastic pipes are prohibited and metal pipes are mandatory (unless specified otherwise).

97.08 Triggering

The means of triggering must be marked with a letter "E" in red inside a white circle of at least 10 [cm] diameter with a red edge.

97.09 Nozzle

The injector nozzles shall be free of sharp, sharp contact and its nozzles shall not be facing towards the occupants.

97.10 Safety pin

The extinguisher safety pin must be removed before starting for the selective sectors, easily visible and marked with a red tape of 20x200 [mm] (as shown below). This procedure will always be checked by the stewards at the start as well as at any other time during the qualifying sections. Failure to comply with this safety procedure will result in penalties to be set by the jury.



01.98 LIGHTS

98.01 General

The lighting equipment must be approved according to the ECE R38 road standard (or an equivalent or stricter standard from another country).

The lights must be constantly switched on during the running of the selective sections.

All the lighting equipment must be maintained in perfect working order throughout the entire duration of the competition.

98.02 Mandatory lights

Each vehicle must be fitted with at least:

- 2 headlights (combined passing lights/headlights)
- 2 front lamps
- 2 rear lamps and number plate lighting
- 2 stop lights with a minimum surface of 50 [cm²]
- 4 flashing indicators, two at the front and two at the rear
- Distress lights (Warning)
- 2 additional red rear fog lamps twinned or placed side by side with a minimum height of 1.25 [m] from the ground attached to the outside of the vehicle.

98.03 Additional lights

Two additional headlights may be fitted, provided that they are not situated more than 250 [mm] above the base of the windscreen.

They may be housed inside the supports of the external rear view mirrors.

The two headlamps and the additional lamps must be located in front of the axis of the front wheels, at a maximum height corresponding to that of the line of the bonnet/bottom of the windscreen (8 lamps maximum).

01.99 DRIVER AND CO-DRIVER EQUIPMENT

The compulsory clothing equipment per occupant is: fire retardant suit, fireproof boots, hood and fireproof gloves.

The use of Head and Neck Support "HANS" or alternative homologated Frontal Head Restraint "FHR" system (including the helmet) is compulsory. It is not allowed to drive without the use of these mandatory elements the race.

99.01 Helmets

The helmets must conform to the following standards:

- SNELL SA 2010
- SNELL SAH 2010
- SNELL SA 2015
- SNELL SA 2020
- SFI - 31.2A Full face design

Diagrams

QUADS	GROUP G (2WD)	GROUP H (4WD)
Max. overall width (mm)	1.300 1.350	1.450
Max. rim diameter (inches)	12	15
Max. seat height (mm)	950	1.100
Handlebar width (min-max, mm)	650	800

max overall width 1.450 mm (Group H)

max overall width ~~1.300~~ 1.350 mm (Group G)

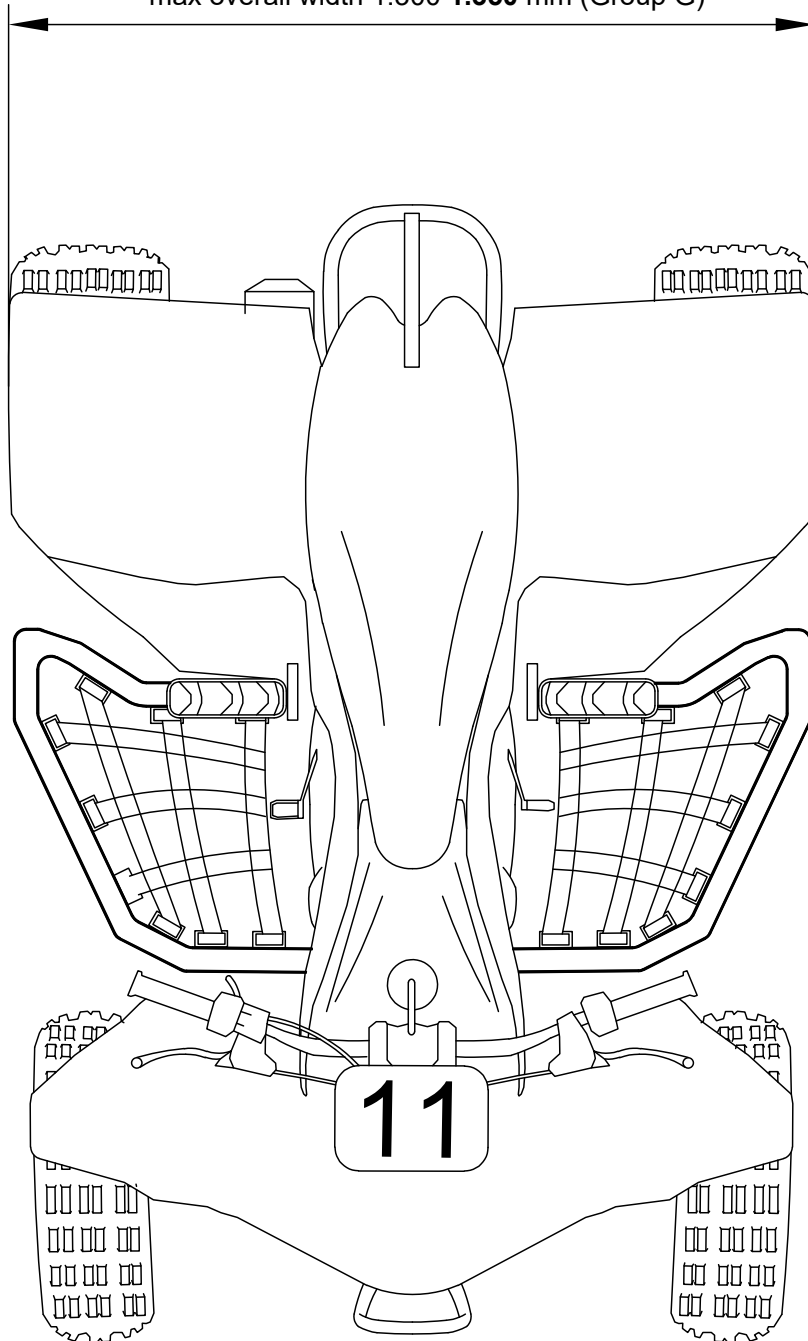

min 600 mm
max 850 mm

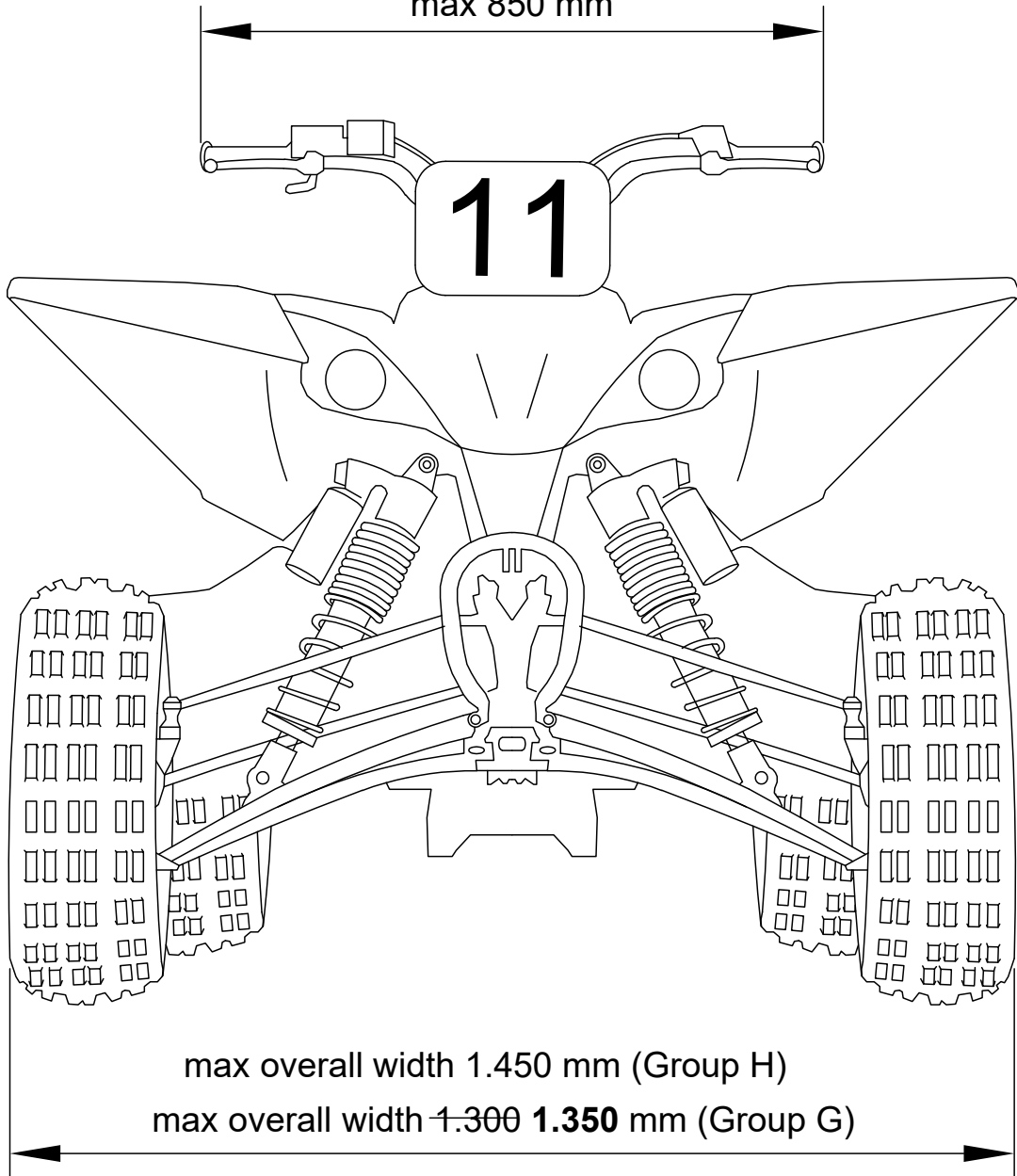

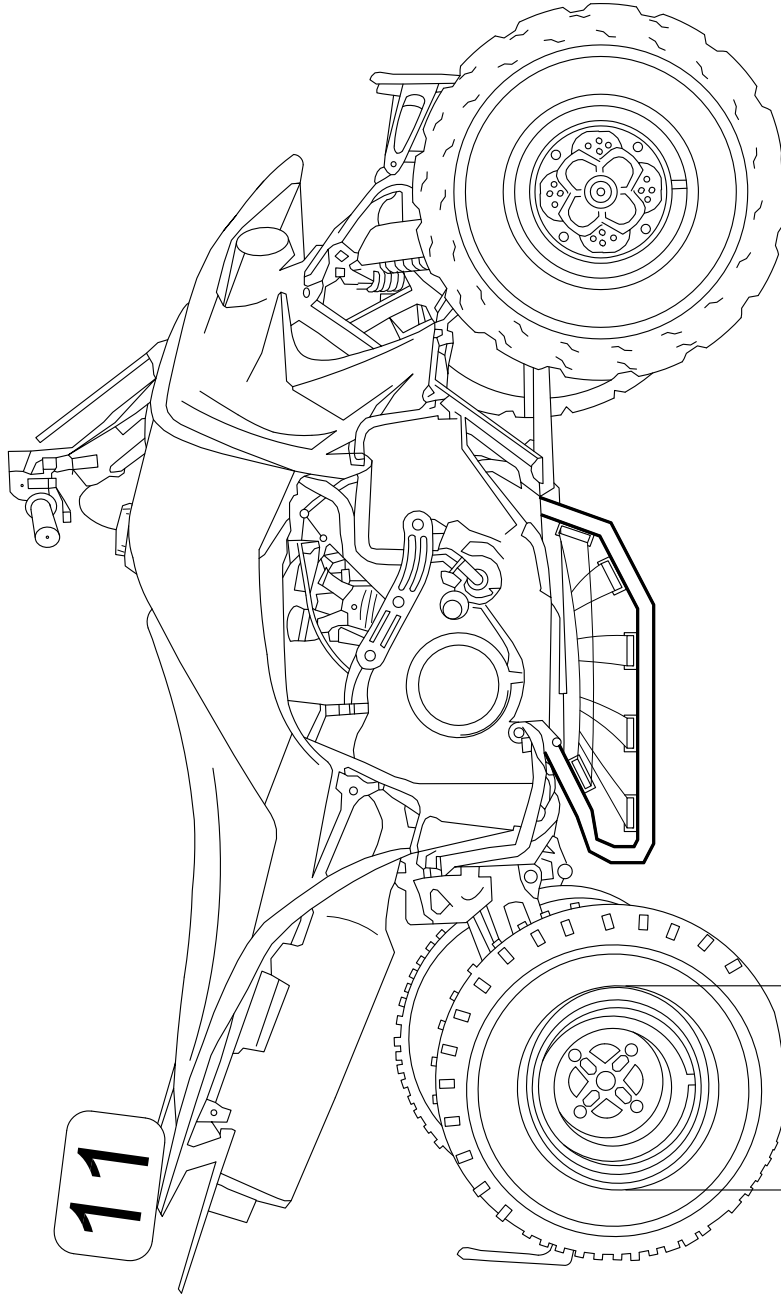

wheel rim
diameter
max 12" (Group G)
max 15" (Group H)

DIAGRAMME Q (suite)

PROTECTIVE DEVICES (REAR) : sprocket and disc SYSTEMES DE PROTECTION (AR): couronne et disque

- (1) Chain guard, mounting to a height corresponding to minimum 90°
Sabot inférieur remontant à la hauteur correspondant à 90° minimum

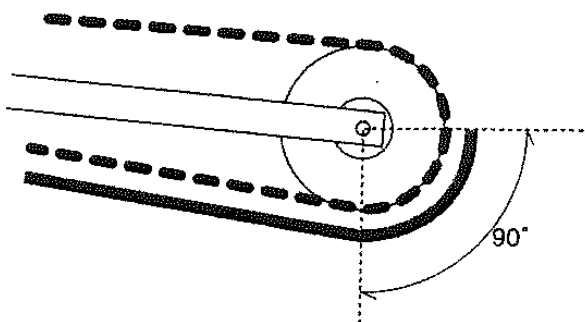

- (2) Chain guard + (3) protective guard
Sabot inférieur + (3) barre de protection

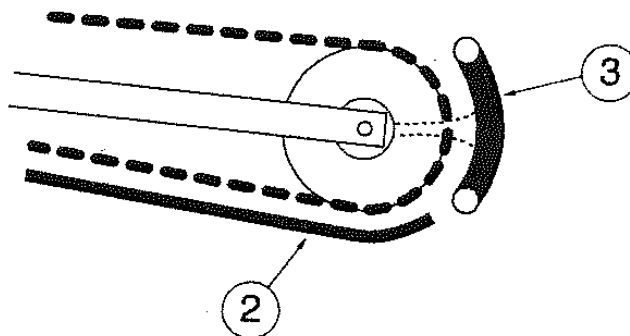

NUMBERS / NUMEROS

0

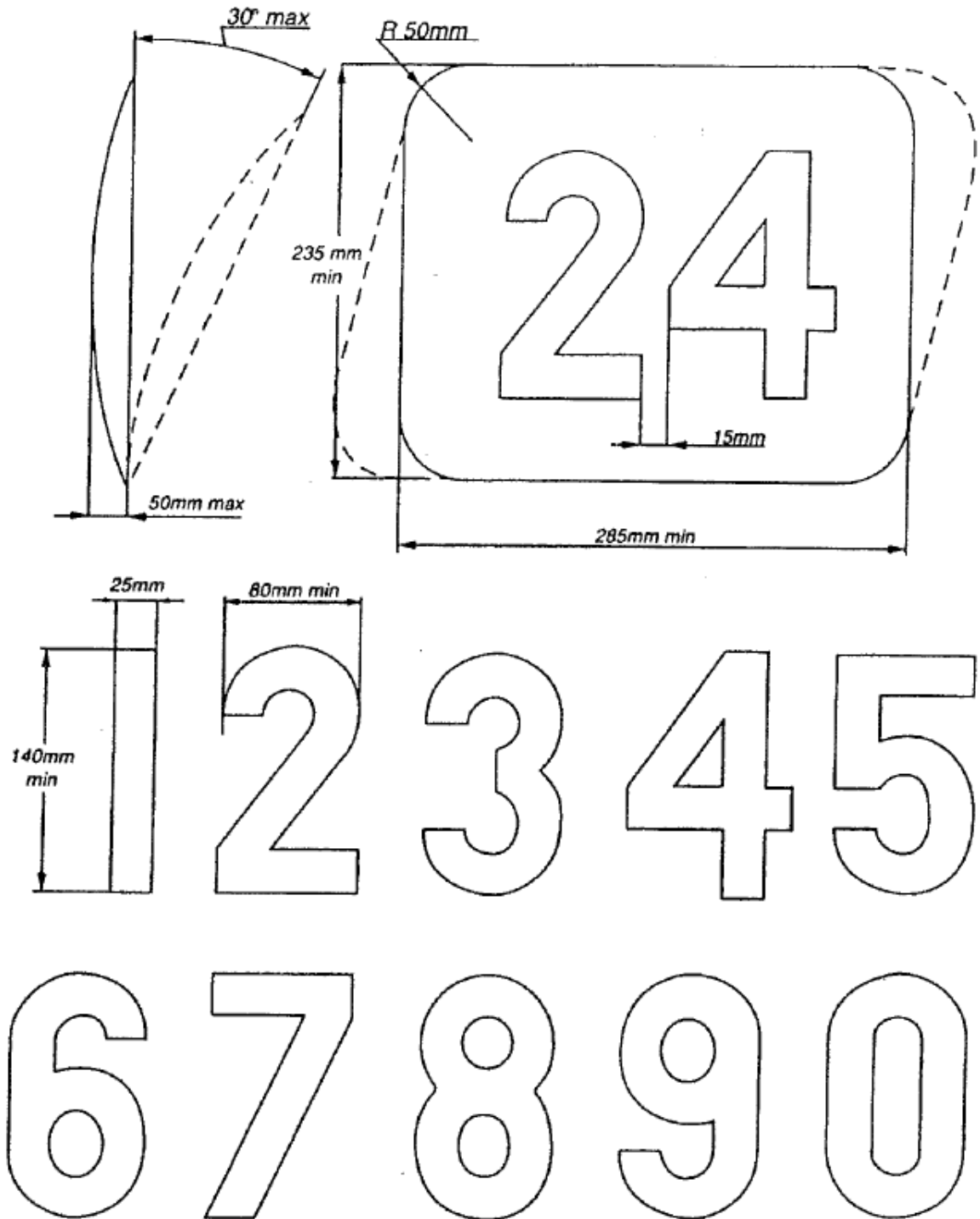

TEN FITTING TESTS FOR HELMETS **DIX TESTS D'ADAPTATION POUR LES CASQUES**

1. *Obtain correct size by measuring the crown of the head*
Avoir la bonne grandeur en mesurant le sommet de la tête
2. *Check there is no side to side movement*
Vérifier qu'il n'y ait pas de déplacement d'un cote l'autre
3. *Tighten strap securely*
Serrer solidement la jugulaire
4. *With head forward, attempt to pull up back of helmet to ensure helmet cannot be removed this way*
Tête en avant, essayer de soulever le casque pour s'assurer qu'il ne peut pas être enlevé de cette façon



5. *Check ability to see clearly over shoulder*
Vérifier si vous pouvez voir clairement par-dessus l'épaule
6. *Make sure nothing impedes your breathing in the helmet and never cover your nose or mouth*
S'assurer que rien ne gêne votre respiration dans le casque et ne jamais couvrir le nez ou la bouche
7. *Never wind scarf around neck so that air is stopped from entering the helmet. Never wear scarf under the retention strap*
Ne jamais enrouler une écharpe autour du cou, car cela empêche l'air d'entrer dans le casque. Ne jamais porter d'écharpe sous la jugulaire
8. *Ensure that visor can be opened with one gloved hand*
S'assurer que la visière peut être ouverte avec une main gantée
9. *Satisfy yourself that the back of your helmet is designed to protect your neck*
S'assurer que l'arrière de votre casque a une forme telle qu'il vous protège la nuque
10. *Always buy the best you can afford*
Toujours acheter le meilleur que vous pouvez vous offrir



*FEDERATION INTERNATIONALE
DE MOTOCYCLISME*

FIM-MOTO.COM

ROUTE DE SUISSE 11 | 1295 MIES | SWITZERLAND

cti@fim.ch

6579007



*FEDERATION INTERNATIONALE
DE MOTOCYCLISME*

**FIM SOUND
REGULATIONS**

2026

FIM SOUND REGULATIONS

Règlement FIM pour le son

Modifications log		
Updated	Applicable as from	Modified articles
0	01.01.2026	

Articles amended as from 01.01.2026 are in bold type
Articles amended during the 2026 season are in bold and red type or strike

Table of Contents

- A. INTRODUCTION..... 3
- B. PREPARATION OF THE SOUND METER..... 4
- C. SET UP OF THE MEASUREMENT 4
- D. TEST PROCEDURE 9
- E. SOUND LIMITS..... 14
 - 1. TRIAL World Championships, Cups and Prizes 14
 - 2. TRACK RACING World Championships, Cups and Prizes 14
 - 3. FLAT TRACK World Championships, Cups and Prizes 14
 - 4. ENDURO, SUPERENDURO, HARDENDURO World Championships, Cups and Prizes 14
 - 5. SAND RACES World Championships, Cups and Prizes 15
 - 6. CROSS-COUNTRY RALLIES & BAJAS World Championships and Cups 15
 - 7. MOTOCROSS World Championships, Cups and Prizes 15

A. INTRODUCTION

In order to pursue the measures taken to reduce the sound level in favour of environment and in the framework of the 'RIDE QUIET' campaign, a new method for measuring the sound level called "2 metre max" is applied as from 2013 in all 'all-terrain' disciplines.

For the first World Championship event, all competitors' motorcycles will be checked for sound level. After the first event, the motorcycles of a 'wild card-' or 'one event' rider, will be checked for the sound level, as well as any other rider's motorcycle on a random basis. Excessively loud motorcycles must always be checked, regardless of the participants' status.

The technical specifications and the resources to apply such a method, for the use of the technical stewards and officials, are outlined in the present article.

The FIM and the FIM Technical Director and his/her appointed staff cannot be held liable for any potential damages or defects which may occur to the motorcycles or any objects/devices tested as well as to the persons present on site during the FIM Sound control procedure.

The "2 metre max" method shows a very good correlation between the sound power level (LWA) issued by motorcycles in full acceleration, and the maximum sound pressure levels measured at proximity of the same motorcycles, with engines at idle and quickly taken to their maximum rotational speeds.

The "2 metre max" method will consist in quantifying not only the sound level produced by the silencer of the exhaust, but the maximum global sound level achieved by the motorcycle when the engine rpm's are raised to the maximum engine speed, limited by a natural regulation (for 2 strokes) or rev limiters (for 4 strokes).

Only the sound levels measured with the "2 meter max" method will be considered by the technical stewards and by the Race Direction/Jury of the event to decide whether the motorcycle is in conformity with the maximum sound levels authorised.

For Motocross disciplines, Enduro/SuperEnduro/HardEnduro, Sand Races, Cross-Country Rallies and Bajas:

Before the opening of the season, the manufacturers must declare to the FIM International Technical Commission (CTI) at cti@fim.ch the maximum power rpm value of the engine of their motorcycles (in standard 'production' specification as sold on the market). The minimum threshold of rpm applied for each class for the sound control procedure will be defined and communicated by the FIM Technical Director.

No modification (in any possible way) of the original RPM channel is allowed. During the sound control, the engine must be able to reach its maximum admissible RPM level (meaning at least the minimum rpm set for each class by the FIM Technical Director according to the information provided by the manufacturers) in Neutral or In Gear position of the gearbox (at the discretion of the Sound Control Officer (SCO)).

The motorcycles fitted with ECU map select switches, all switch positions may be tested.

Furthermore, all systems of dB-Killers must be either the original part delivered by the exhaust manufacturer or made in a safe and professional (well-engineered) way. In case of dispute, the decision of the FIM Technical Director will be final.

B. PREPARATION OF THE SOUND METER

For all FIM championships and prizes, sound level meters must conform to the frequency response tolerance for Class 1 or Class 2 for nominal frequencies between 125Hz to 8000Hz, as stated by the IEC 61672-1:2013 subsection 5.5 standard.

All sound level meters must also conform to the tolerance for Class 1 or Class 2 for amplitude linearity, for its specified class, as stated by the IEC 61672-1:2013 subsection 5.6 standard. IEC 61672 is a regulatory document, which covers specifications and qualification requirements for class 1 and class 2 sound level meters.

Two sets of equipment must be available in case of failure of tachometer, sound level meter or calibrator during technical control.

Sound level measuring equipment must also include:

- a compatible calibrator, which must be used immediately before testing begins and always just prior to a re-test if a disciplinary sanction may be imposed;
- a tachometer.

The sound meter shall be prepared by applying the following procedure:

1. Activate the 'A' weighing
2. FAST time weighting must be activated
3. Select the highest range available (ex. 80~130 [dB])
4. Calibrate the sound meter according to the instructions, taking into account the incidence of the wind foam ball
5. Position the wind foam ball on the microphone
6. Activate the function MAX MIN – set on MAX

C. SET UP OF THE MEASUREMENT

The sound levels will be measured with the microphone fixed on a tripod at a height of 1.35 m above the ground, in horizontal (levelled) position. It is helpful to have the microphone equipped with an extension cable to the sound meter.

For the place and position of the motorcycle, ensure that there are no solid obstacles within 10 m around the microphone.

Depending on the vehicle, the sound meter will be positioned:

for Solo motorcycles: at an angle of 45° from the longitudinal axis of the vehicle, on the exhaust side, at a distance of 2 m behind the vehicle (measured from the point where the centre of rear tyre touches the ground).

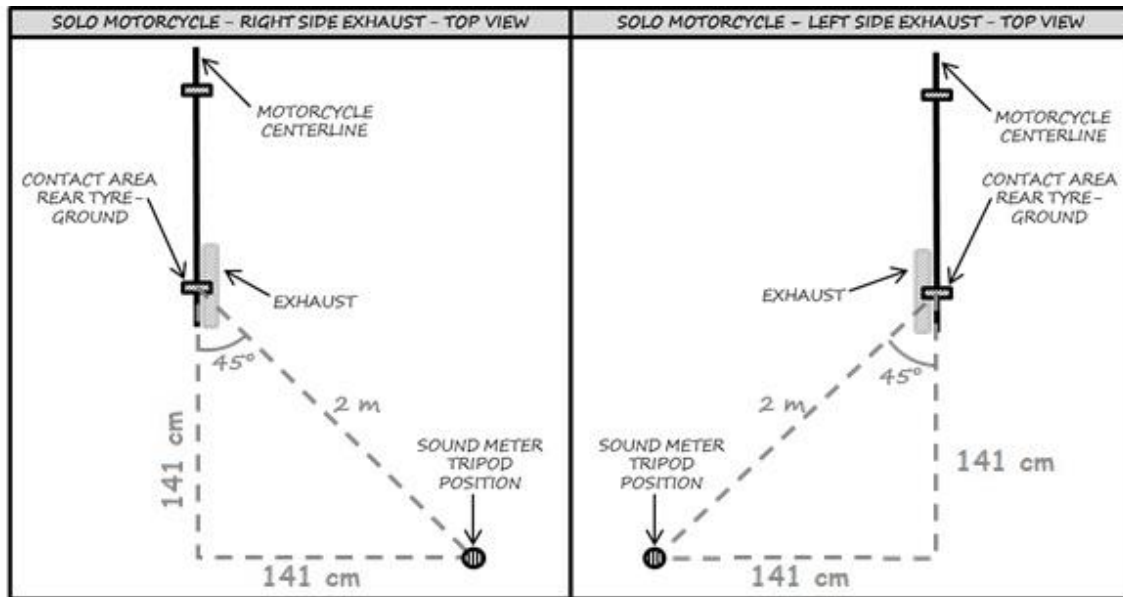

Figure 1 : Sound meter position for solo motorcycle

for Solo motorcycles with 2 exhaust outputs: at an angle of 45° from the longitudinal axis of the vehicle, on the side of the air intake, at a distance of 2 m behind the vehicle (measured from the point where the centre of rear tyre touches the ground). Note: if a central positioned air intake is used, both sides will be tested.

for Snowmobiles: at an angle of 90° from the longitudinal axis of the vehicle, on the side of the silencer, at a distance of 2 m next to the vehicle (measured from the silencer exit). For continuity of the measurement, use the handlebar as a reference to line up the motorcycle with the microphone - the exhaust pipe is usually located on the right hand side of the motorcycle and directly under the handlebar position. Note: the use of only one silencer is allowed for Snowmobiles.

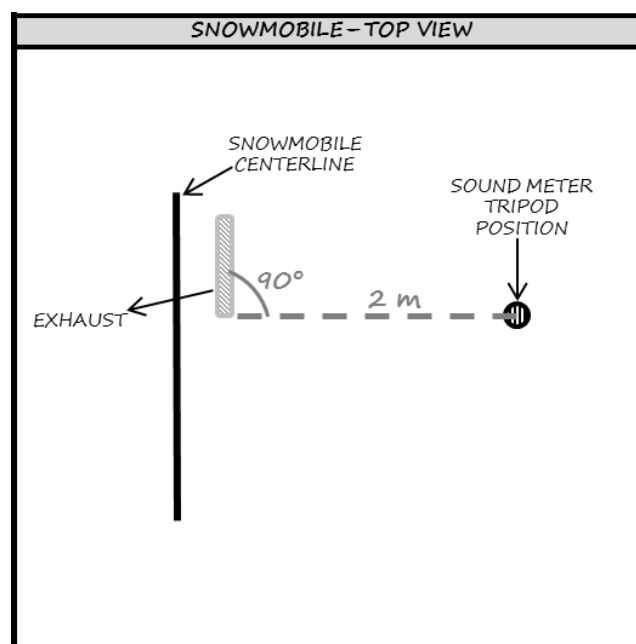

Figure 2: Sound meter position for solo snowmobile

for Sidecars: at an angle of 45° from the longitudinal axis of the vehicle, on the sidecar side, at a distance of 2 m behind the vehicle (measured from the point where the sidecar tyre touches the ground). If the exit of the silencer is closer to the motorcycle rear wheel, the reference point will be the contact point of the motorcycle rear wheel on the ground (as for Solo motorcycles).

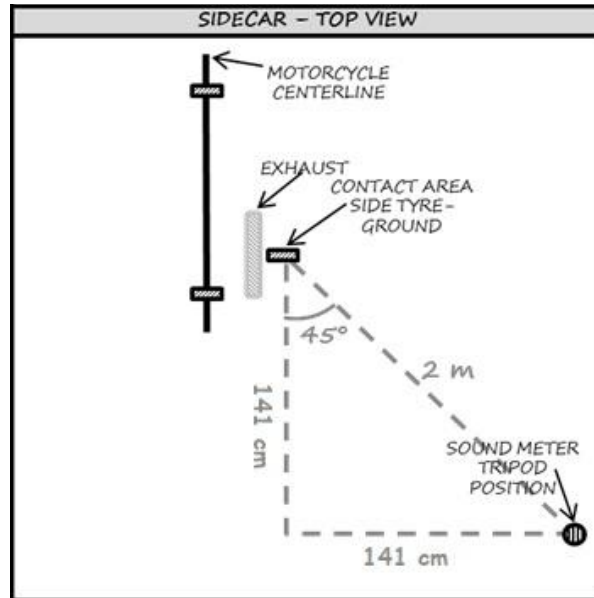

Figure 3: Sound meter position for sidecars

for Quads: at an angle of 45° from the median longitudinal axis of the vehicle, at a distance of 2 m behind the vehicle (measured from the point where the line drawn perpendicular to the rear axle touches the ground).

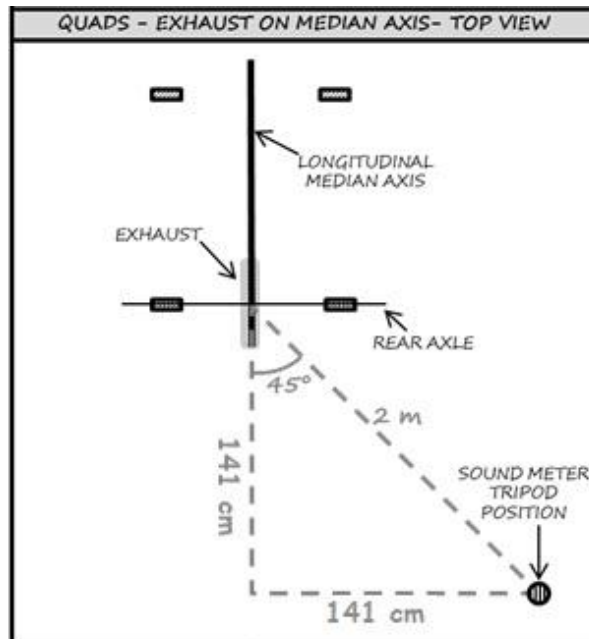

Figure 4: Sound meter position for quads

for Quads with the exhaust moved out of the median axis: at an angle of 45° from the rear axle, from where the rear axle and the exhaust meet, at a distance of 2 m behind the vehicle (measured from the point where the line drawn perpendicular to the rear axle touches the ground).

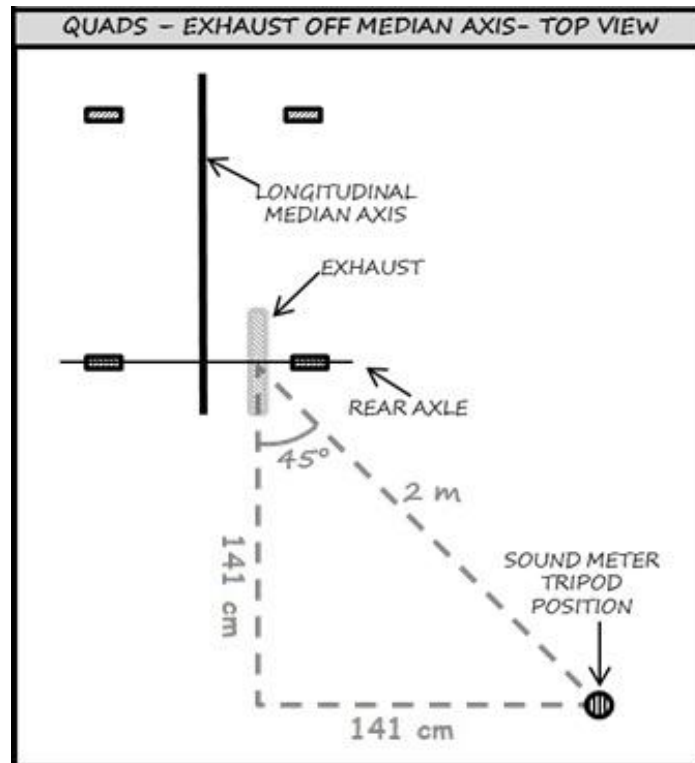

Figure 5: Sound meter position for solo motorcycle with exhaust moved out of the median axis

The sound level for engines with more than one silencer will be measured on each exhaust end.

Silencers fitted with adapters aiming to reduce the sound level shall be permanently fitted.

To make repetitive measurements, all motorcycles can be positioned into a small frame fixed on the ground, making sure to respect the 45° requirements. A squared frame helps the positioning of the motorcycle.

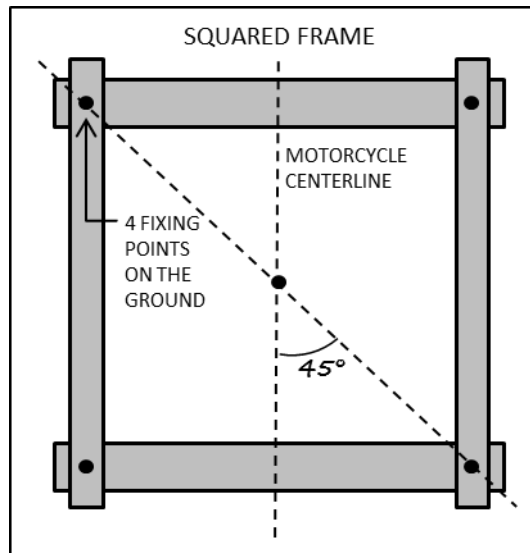

Figure 6 : Squared frame design

Vehicles which are not equipped with a gear box neutral must be placed on a stand.

It is preferred to make the tests on soft ground, not reverberating, i.e. grass or fine gravel.

We strongly recommend to the SCO, when practically possible, to always perform the sound measurements with the wind from backward to forward based on the motorcycle position (in favor of the rider). Please see hereunder:

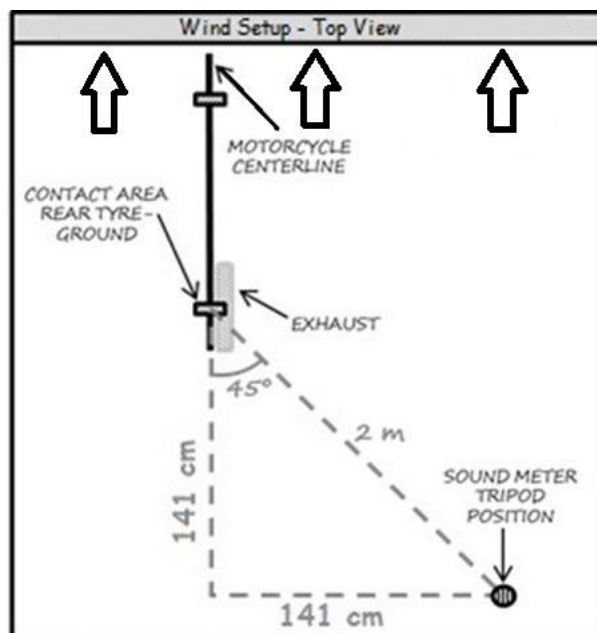

Figure 7 : Setup during windy conditions

The ambient sound at the point of measurement must be minimum 15 [dB/A] less than the lowest FIM sound limit applied in each discipline.

It is recommended to re-calibrate the sound meter before starting measurements and before putting the system away except when there has been any accident (physical

impact to the equipment). In the event of an impact, the sound meter must be systematically re-calibrated before restarting any measurements.

D. TEST PROCEDURE

The Sound Control Officer (SCO) must be holder of a valid FIM Technical Stewards' license, come with good knowledge and experience of the sound control and application of the test method. The FMNR may propose the services from a special technician (acoustic engineer) if there is no FIM licenced Technical Steward available to act as SCO.

The SCO must have arrived in sufficient time for discussions with the Clerk of the Course/FIM Race Director and other Technical Officials in order that a suitable test site and testing procedure can be agreed.

The SCO (identified as "SCO" on the drawing here under) must be positioned on the right side of the vehicle, between the handlebar and the footrest, managing the throttle grip during the whole sound control procedure. During the sound control procedure, nobody can stand in the grey "prohibited" area between the muffler and the microphone area defined by the following drawing:

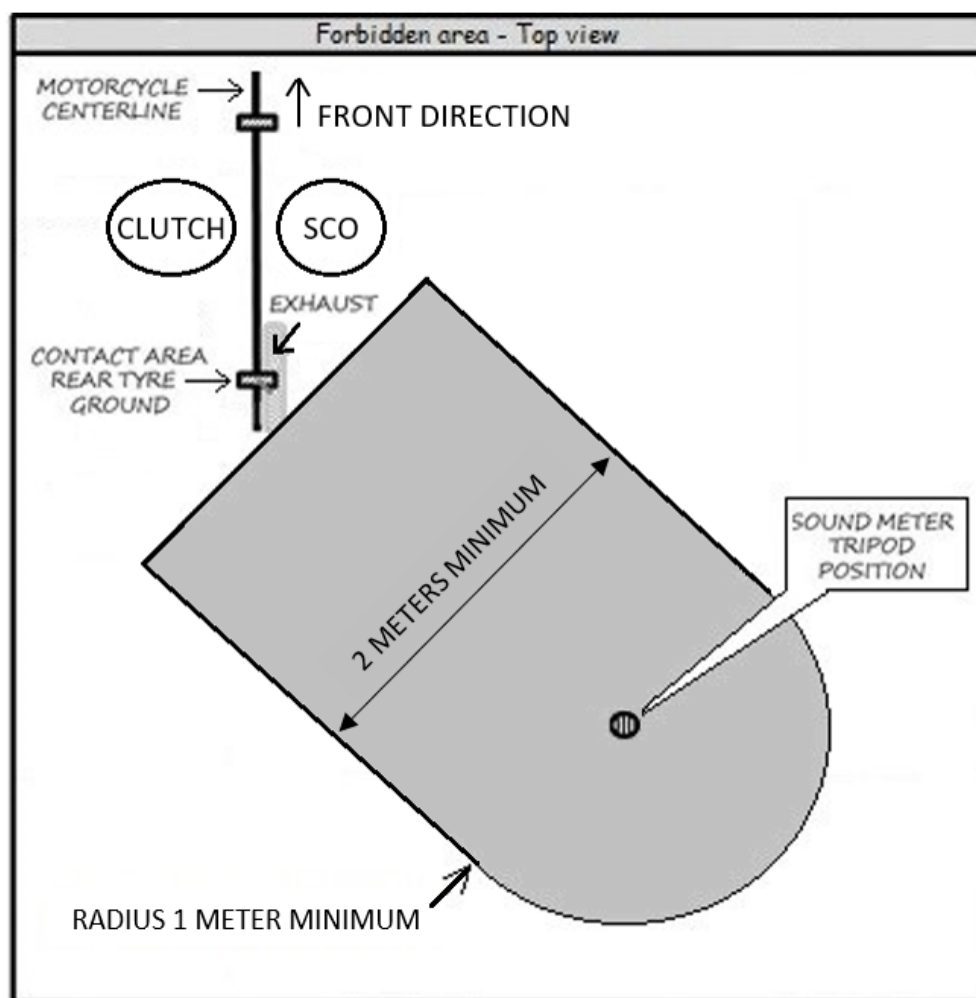

Figure 8 : Prohibited area during the Sound Control

A second technical steward can be present to help. The rider can also be present.

It is strongly advised that the technical steward(s) use earplugs, a headset or ear protectors.

The measurements are made with motorcycle on its wheels, with a hot engine, whatever in neutral gear position or in-gear position (at the discretion of the SCO). During the sound test, only the rider may sit on the vehicle in the normal riding position (at the discretion/decision of the SCO). For safety reasons, we recommend to the SCO to always keep the rear brake pedal under pressure during the sound control procedure.

The CLUTCH: a rider, a mechanic (or a second FIM/FMNR technical steward where compulsory (example: MXGP)) identified as "CLUTCH" on the drawing here above, positioned on the left side of the vehicle, between the handlebar and the footrest, shall disengage the clutch during the whole sound control procedure.

The SCO (and not others) shall open the throttle as fast as possible (instantly, within 0.3 s) until "full open throttle", in order to reach the maximum rpm value ("max. rpm").

For Motocross, Enduro/SuperEnduro/HardEnduro, Cross-country rallies/Bajas, Sand Races and Track Racing motorcycles with no FIM homologated silencers, the "max rpm" is the one defined by the ECU (for 4-stroke engines), or by a natural regulation (for 2-stroke engines).

When in doubt, it can be verified that such "max. rpm" value is higher than the rpm value at which the vehicle supplies its maximum power (kW) ("max. power rpm").

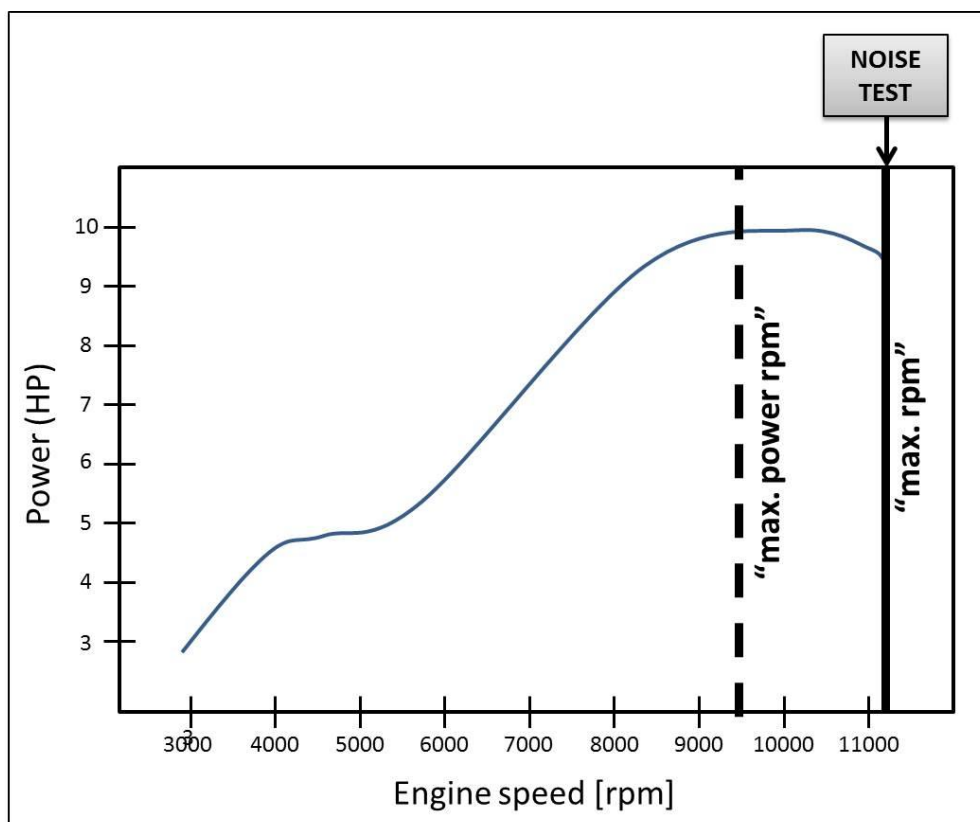

For Trial, the "max rpm" is established at 10000 (± 200) rpm and obtained thanks to a dedicated "sound test" mapping of the internal ECU or an external one, purpose-made and connected in occasion of the test.

For Track Racing with FIM homologated silencers, when sound tests are needed, the "max rpm" is established at 11000 (± 500) rpm.

The SCO then keeps the engine at the "max. rpm" value for at least 1 s (or until there is an audible sign of over-revving the engine), during which the measurement is taken.

To conclude the test, the SCO releases the throttle quickly.

The maximum noise value (dB/A) registered during the measurement interval is then read on the sound meter and recorded. This noise value shall not be rounded down to the nearest whole number.

The noise value is then compared with the sound limits (see **Art. E**).

The noise test can be "**PASSED**" or "**NOT PASSED**":

"PASSED": The sound test is considered "passed" if the recorded noise value is below or equal to the sound limits of **Art. E**. The silencer can then be marked by the SCO at the end of the test.

The silencer can be changed after verification under the conditions of technical control.

The end opening of the silencer shall remain unmodified once it has been checked and marked.

"NOT PASSED": The sound test is considered "not passed" if the recorded noise value is above the sound limits of **Art. E**.

In this case, the vehicle (with the same silencer) can be presented again, but for two more tests maximum. If the third test result is negative, the rider can present a different or repaired silencer (in case the sound test was done before the race) will receive a penalty (in case the sound test was done during or after the race).

The sound meter is then reset by pushing on the side-line and armed by pushing on the side-line again.

Sound controls during the event or after the race:

- the motorcycle must be tested in the exact conditions at any time of the event when the FIM Technical Director requests the team/rider for a sound control.
- the motorcycle must be tested in the conditions it has finished the race and has rejoined the parc fermé.

Notes:

If the engine starts to misfire, close the throttle slightly and re-open the throttle.
If detonations appear, the measurement must be started again.

For vehicles without an engine rev. limiter, the throttle will have to be opened not more than 2 s or until there is an audible sign of over-revving the engine.

Even in case a vehicle has not exceeded the respective sound limit, if there is any doubt, the vehicle may be checked again.

If the vehicle is unable to reach the "max. power rpm" value, the vehicle shall be refused. Any attempt by a participant to prevent his engine from reaching the "max. power rpm" will be considered a breach of the rules.

In case the SCO doubts that the "max. power rpm" value (as declared by the manufacturers or previously obtained with the dyno test), he/she shall measure the engine speed with a tachometer connected to the spark.

The motorcycle must maintain at least the minimum RPM during the sound controls. Any motorcycle that is unable to reach and maintain the minimum RPM stated will be refused (applicable with the Race Patrol (/Lite) sound meter from EA LAB (or any other RPM readers)). In case of dispute, the decision of the FIM Technical Director will be final:

Minimum RPM thresholds		
Motocross, Supermoto, RallyGP & Sand Races		
50 cc 65 cc	2T	11500 rpm
65 cc to 85 cc		11500 rpm
100 cc to 125 cc		11000 rpm
175 cc to 300 cc		9000 rpm
85 cc to 150 cc	4T	13500 rpm
175 cc to 250 cc		13500 rpm
290 cc to 350 cc		12000 rpm
450 cc		10800 rpm
Sidecarcross		
	2T	8000 rpm
	4T	9000 rpm
Snowcross		
	2T	8000 rpm
	4T	TBC rpm
Quadcross		
up to 500 cc	2T	9000 rpm
up to 450 cc	4T	10400 rpm
451 - 500 cc	4T	9000 rpm

Enduro. Rally 2, Rally 3		
up to 125 cc	2T	11000 rpm
Over 125 cc		9000 rpm
up to 250 cc	4T	12000 rpm
250 - 350 cc		11000 rpm
350 - 450 cc		10000 rpm
Over 450 cc		9000 rpm
Quads		
TBC		TBC rpm
Trail		
Over 600 cc		TBC rpm
Flat Track		
250 - 500 cc	2T	9000 rpm
250 - 450 cc	4T	10800 rpm

Rain and wet conditions significantly alter the laws under which sound propagates. For the risk of misleading results and unrepeatable conditions, sound testing should not be performed when it is raining or conditions are wet. The decision of the Sound Control Officer and/or FIM technical Director to continue, suspend or stop the sound controls in rainy/wet conditions is final.

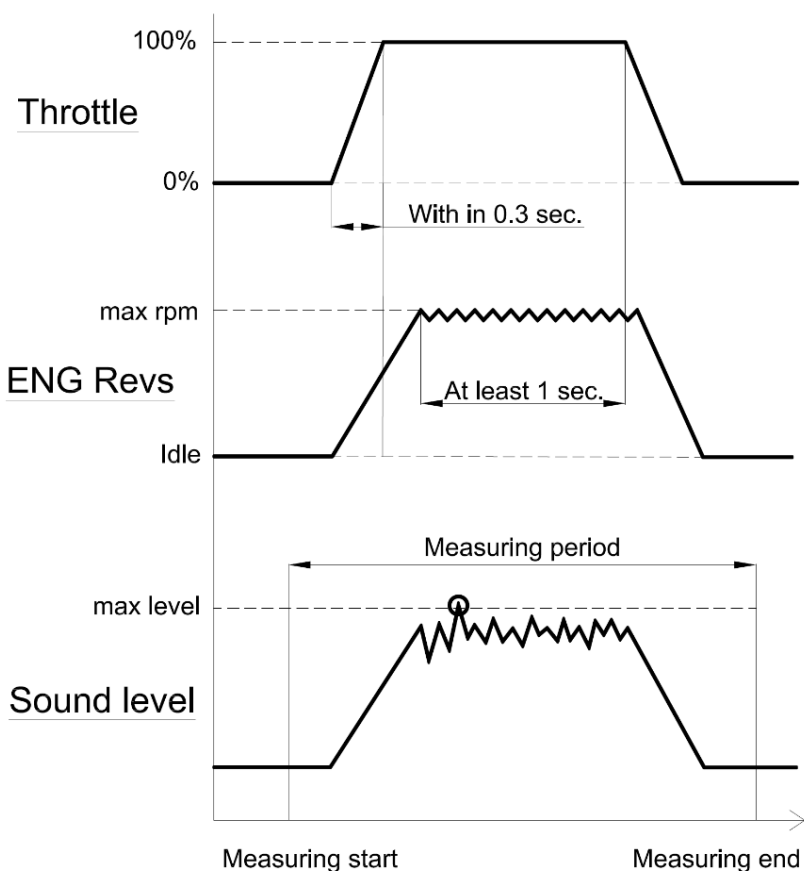

1. The Inspector shall open the throttle until full open throttle within 0.3 seconds.
2. And keep at the max rpm (at rpm limiter) at least 1 second. Then, release the throttle quickly.
3. The sound level is measured in the all period and the maximum level shall be recorded in any case. (automatically by the sound meter).

E. SOUND LIMITS

Below are listed the maximal sound limits by category and by type of engine.

- The values that have to be respected after the race take into account the degradation of the silencer (i.e. the limit is raised of 1 dB/A).
- The values already take into account the accuracy of the method.
- No deductions for ambient temperature, wind, pressure or altitude are allowed.
- The measured noise value shall not be rounded down to the nearest whole number.

1. TRIAL World Championships, Cups and Prizes

Type of engine	Maximum Sound limit in [dB/A]	
	Before the race	During or after the race
2-stroke	103.0	104.0
4-stroke	105.0	106.0

Table 1 : Sound limit for Trial

2. TRACK RACING World Championships, Cups and Prizes

Type of engine	Maximum Sound limit in [dB/A]	
	Before the race	During or after the race
All	115.0	116.0
2-stroke 4-stroke	(Target 113.0 + 2.0 for the precision of the method)	(Target 115.0 + 1.0 for the degradation of the silencer)
SGP4 4-stroke	111.0 (Target 109.0 + 2.0 for the precision of the method)	112.0 (Target 111.0 + 1.0 for the degradation of the silencer)

Table 2: Sound limit for Track Racing

3. FLAT TRACK World Championships, Cups and Prizes

Type of engine	Maximum Sound limit in [dB/A]	
	Before the race	During or after the race
All	113.0	114.0
2-stroke 4-stroke	(Target 111.0 + 2.0 for the precision of the method)	(Target 113.0 + 1.0 for the degradation of the silencer)

Table 3: Sound limit for Flat Track

4. ENDURO, SUPERENDURO, HARDENDURO World Championships, Cups and Prizes

Type of engine	Maximum Sound limit in [dB/A]	
	Before the race	During or after the race
All	111.0	112.0
2-stroke 4-stroke	(Target 109.0 + 2.0 for the precision of the method)	(Target 111.0 + 1.0 for the degradation of the silencer)

Table 4: Sound limit for Enduro, SuperEnduro, HardEnduro

5. SAND RACES World Championships, Cups and Prizes

Type of engine	Maximum Sound limit in [dB/A]	
	Before the race	During or after the race
All 2-stroke 4-stroke	112.0 (Target 110.0 + 2.0 for the precision of the method)	113.0 (Target 112.0 + 1.0 for the degradation of the silencer)
Quads: 2-stroke 4-stroke	112.0 (Target 110.0 + 2.0 for the precision of the method)	113.0 (Target 112.0 + 1.0 for the degradation of the silencer)

Table 5: Sound limit for Sand Races (from 16/02/2026)

As of 01/01/2027:

Discipline/Class	Maximum Sound limit in [dB/A]	
	Before the race	During or after the race
Quads: 2-stroke 4-stroke	111.0 (Target 109.0 + 2.0 for the precision of the method)	112.0 (Target 111.0 + 1.0 for the degradation of the silencer)

Table 6: Sound limit for Sand Races Quads as from 01/01/2027

6. CROSS-COUNTRY RALLIES & BAJAS World Championships and Cups

Type of engine	Maximum Sound limit in [dB/A]	
	Before the race	During or after the race
All 2-stroke 4-stroke	117.0 (Target 115.0 + 2.0 for the precision of the method)	118.0 (Target 117.0 + 1.0 for the degradation of the silencer)

Table 7: Sound limit for Cross-Country Rallies & Bajas

7. MOTOCROSS World Championships, Cups and Prizes

Discipline/Class	Maximum Sound limit in [dB/A]	
	Before the race	During or after the race
MXGP, MX2, Women MX: 2-stroke 4-stroke	111.0 (Target 109.0 + 2.0 for the precision of the method)	112.0 (Target 111.0 + 1.0 for the degradation of the silencer)
Supercross (SX): 2-stroke 4-stroke	114.0 (Target 112.0 + 2.0 for the precision of the method)	115.0 (Target 114.0 + 1.0 for the degradation of the silencer)
Sidecarcross: 2-stroke 4-stroke	111.0 (Target 109.0 + 2.0 for the precision of the method)	112.0 (Target 111.0 + 1.0 for the degradation of the silencer)
Junior MX: 2-stroke (65/85) 2-stroke (125) 4-stroke	111.0 (Target 109.0 + 2.0 for the precision of the method)	112.0 (Target 111.0 + 1.0 for the degradation of the silencer)
Supermoto: 2-stroke 4-stroke	111.0 (Target 109.0 + 2.0 for the precision of the method)	112.0 (Target 111.0 + 1.0 for the degradation of the silencer)

Snowcross: 2-stroke 4-stroke	111.0 (Target 109.0 + 2.0 for the precision of the method)	112.0 (Target 111.0 + 1.0 for the degradation of the silencer)
Quadcross: 2-stroke 4-stroke	114.0 (Target 112.0 + 2.0 for the precision of the method)	115.0 (Target 114.0 + 1.0 for the degradation of the silencer)

Table 8: Sound limit for Motocross

As of 01/01/2027:

Discipline/Class	Maximum Sound limit in [dB/A]	
	Before the race	During or after the race
Quadcross: 2-stroke 4-stroke	111.0 (Target 109.0 + 2.0 for the precision of the method)	112.0 (Target 111.0 + 1.0 for the degradation of the silencer)

Table 9: Sound limit for Quadcross as from 01/01/2027

- The values that have to be respected after the race take into account the degradation of the silencer (i.e. the limit is raised of 1 dB/A).
- The values already take into account the accuracy of the method.
- No deductions for ambient temperature, wind, pressure or altitude are allowed.
- The measured noise value shall not be rounded down to the nearest whole number.



**FEDERATION INTERNATIONALE
DE MOTOCYCLISME**

FIM-MOTO.COM

ROUTE DE SUISSE 11 | 1295 MIES | SWITZERLAND

cti@fim.ch

6579006



*FEDERATION INTERNATIONALE
DE MOTOCYCLISME*

**FIM FUELS
REGULATIONS**

2025

FIM Fuels Regulations

Règlement FIM pour les essences

Modifications log		
Version	Applicable as from	Modified articles
0	01.01.2025	

Articles amended for the season 2025 are in bold type
Articles amended since 01.01.2025 are in red and bold type



Table of Contents

A.	INTRODUCTION	3
B.	REGULAR FUEL	4
C.	RACE FUELS	5
D.	TESTING LABORATORY	6
E.	FIM FUEL SPECIFICATION - CATEGORY 1	7
F.	FIM FUEL SPECIFICATION - CATEGORY 2	9
G.	FIM FUEL SPECIFICATION - CATEGORY 3	11
H.	FIM FUEL SPECIFICATION - CATEGORY 4	12
I.	FIM SPECIFICATIONS FOR MIXTURES OF UNLEADED FUEL(S) AND LUBRICANT	13
J.	OXIDANT - AIR	14
K.	FUELS CONTROLS	15
L.	FUEL SAMPLE DECLARATION FORM	20
M.	LIST OF FIM CERTIFIED FUELS	22

A. INTRODUCTION

PLEASE ALWAYS REFER TO THE LATEST FIM REGULATIONS CODE IN FORCE FOR THE DISCIPLINE / COMPETITION (INCLUDING THE SUPPLEMENTARY REGULATIONS)

All machine(s) must be fuelled with a fuel specification compliant with one of the following FIM Fuel specifications:

- Regular Fuels
- Race Fuels - Category 1
- Race Fuels - Category 2
- Race Fuels - Category 3
- Race Fuels - Category 4

For your reference and complete information, please refer to the last update of the reference documents hereunder:

- FIM FUELS REGULATIONS:

https://www.fim-moto.com/fr/documents?tx_solr%5Bq%5D=fuels+regulations

- FIM CERTIFIED FUELS LIST:

https://www.fim-moto.com/fr/documents?tx_solr%5Bq%5D=certified+fuels

Every team has to declare the fuel specification they will use for the entire official event before the technical verifications (on the FIM Technical Control form). If the team use a race fuel, the team must provide the fuel certificate from the FIM appointed testing laboratory to the FIM Technical Directors.

B. REGULAR FUEL

If not specified in the Technical Rules of the Championships, Cup or Prize or in the Supplementary regulation of the event, regular fuel coming from Public Fuel station can be used.

By regular fuel. It is to be understand fuel available at the fuel station with a fuel gun and with an Octane not more than 98. Local official fuel specification will be taken into account depending on the conformity of a pump station fuel.

C. RACE FUELS

Fuel companies which supply “race” fuels (fuels other than those obtained at public pump stations) to participating teams/riders must test their fuel at against all the FIM specifications set out in Art. **E, F, G, H** of this regulation.

Certified fuels

If the specifications of the fuel are in conformity to Art. **E, F, G, H** of this regulation, a certificate containing a test report and batch number will be issued to the fuel company.

The fuel company shall be able to provide a copy of such certificate to their client rider/teams before they take part in a race.

If a team and/or rider uses a Race fuel in their vehicle, it is their full responsibility and obligation to inform the FIM Technical Director (or FMN Chief Technical Steward) during the technical verifications and to present the fuel certificate provided from the FIM appointed Laboratory of that racing fuel.

Please refer to the latest list of the FIM certified fuels on the following link:

https://www.fim-moto.com/en/documents?tx_solr%5Bq%5D=certified+fuels

Appointed supplier(s) to event(s)

In the cases in which only fuel from the appointed supplier is permitted (for a specific event or the entire World Championship, Prize or Cup), the aforementioned fuel shall have been previously tested in a FIM appointed laboratory in order to test its conformity with the FIM specifications as set out in Art. **E, F, G, H** of this regulation:

- in case of conformity, a certificate of conformity (including test report and tested batch number) shall be available and Art. **C, K** of this regulation applies in case of controls for the riders/teams;
- in case the conformity is not achieved, the FMN of the organising country/the Organiser/the Promoter shall ask the FIM for a waiver in order to enable the use of fuel not corresponding to FIM specifications. If the waiver is granted, the riders/teams will be responsible for using the fuel provided without changing its composition. Controls may be carried out by FIM.

D. TESTING LABORATORY

For question regarding the “race” fuels and/or the testing of the fuels please contact the aforementioned testing laboratory:

Intertek (Schweiz) AG

Analytical Testing - Fuel, Lubricants & Combustible

Wagistraße 2

8952 Schlieren

Switzerland

Telephone: +41 43 433 78 10

Fax: +41 43 433 78 19

Email contact: fimfuels@intertek.com.

E. FIM SPECIFICATIONS FOR UNLEADED PETROL, CATEGORY 1

The following fuels specifications are valid for these FIM Competitions (please always refer to the latest regulations code in force for the discipline):

FIM Circuit Racing Competitions:

- MotoGP™
- Moto2™
- Moto3™
- WorldSBK
- WorldSSP NG
- MiniGP
- Redbull Rookies Cup
- Endurance World Championship and Cup
- Women's World Championship

The following properties shall be within the following thresholds (for each property, the relative test methods to be used for the measurement are indicated):

For MotoGP/Moto2/Moto3: this fuel must be a minimum of 40% of non-fossil origin, increasing to 100% of non-fossil origin from 2027.

Property	Units	Test method	Min.	Max.
Non-fossil components	% (14C/C)	ASTM D6866-22 - Method B - AMS	40.0*	
RON		ISO 5164	95.0	102.0
MON		ISO 5163	85.0	90.0
Oxygen	% (m/m)	ISO 22854		3.7
Benzene	% (v/v)	ISO 22854		1.0
Vapour pressure (DVPE)	kPa	EN 13016-1		90.0
Density at 15°C	kg/m ³	ASTM D 4052/ EN 12185	720.0	775.0
Oxidation stability	minutes	ASTM D 525/ EN ISO 7536	360	
Existent gum	mg/100ml	EN ISO 6246		5.0
S	mg/kg	ASTM D 5453/ EN ISO 20846		10.0
N	% (m/m)	ASTM D 4629		0.2
Cu corrosion	Rating	ISO 2160		Class1
Distillation at 70°C	% (v/v)	ISO 3405	22.0	50.0
Distillation at 100°C	% (v/v)	ISO 3405	46.0	72.0
Distillation at 150°C	% (v/v)	ISO 3405	75.0	
Final boiling point	°C	ISO 3405		210.0
Residue	% (v/v)	ISO 3405		2.0
Olefins	% (v/v)	ISO 22854		18.0
Bi/Polycyclic olefins	% (m/m)	GCMS		0.01
Total di-olefins	% (m/m)	GCMS/HPLC		1.0
Aromatics	% (v/v)	ISO 22854		35.0
Total HC's containing only H and C and present <5% each	% (m/m)	Gas chromatography	30.0	
Substances capable of exothermic reaction in absence of external O		GCMS		Not permitted**
Oxygenates other than below list	% (m/m)	EN ISO 22854		0.1

Methanol	% (v/v)	ISO 22854	3.0
Mn content	mg/l	ICPOES or ASTM D3831	1.0
Pb content	mg/l	ICPOES or ASTM D3237	5.0
Fe content	mg/l	EN 16136 :2015 or ASTM D5059 – 20	5.0
Ni content	mg/l	EN 16136 :2015 or ASTM D5059 – 20	5.0
Appearance		Visual inspection	Clear and bright

All reported min. and max. thresholds (except for the non-fossil components determination) do not include the tolerance, which needs to be calculated in accordance with ISO 4259 and taken into account to correct the min. and max. thresholds.

List of permitted oxygenates:

Methanol, Ethanol, Iso-propyl alcohol, Iso-butyl alcohol, Methyl tertiary butyl ether, Ethyl tertiary butyl ether, Tertiary amyl methyl ether, Di-isopropyl ether, n-Propyl alcohol, Tertiary butyl alcohol, n-Butyl alcohol, Secondary butyl alcohol.

*As it is guaranteed that all the samples will be analysed by the same laboratory, an absolute measure uncertainty of +/- 0.5% will be taken in account, as per ASTM D6866- 22 - Method B - AMS.

**A limit of detection of 0.01% m/m will be applied.

Fuel definitions:

- Paraffins Straight chain and branched alkanes.
- Olefins Straight chain and branched monoolefins and diolefins.
- Monocyclic monoolefins (with five or more carbon atoms in the ring) with or without paraffinic side chains.
- Diolefins Straight chain or branched or monocyclic hydrocarbons (with five or more carbon atoms in any ring) with or without paraffinic side chains, containing two double bonds per molecule.
- Naphthenes Monocyclic alkanes (with five or more carbon atoms in the ring) with or without paraffinic side chains.
- Aromatics Monocyclic and bicyclic aromatic rings with or without paraffinic side chains.
- Oxygenates Organic compounds containing oxygen.
- Additive An additive is a component added to the fuel at low concentration to improve a particular property of the fuel. These include (but are not limited to) antioxidants, antiknock agents, antistatic additives and deposit control additives.
- Metals are defined as alkali metals, alkaline earth metals, transition metals, actinides, lanthanides, post-transition metals and metalloids.

F. FIM SPECIFICATIONS FOR UNLEADED PETROL OR MIXTURES OF UNLEADED FUELS, CATEGORY 2

The following fuels specifications are valid all FIM Competitions not included in Category 1, Category 3 and Category 4.

The following properties shall be within the following thresholds (for each property, the relative test methods to be used for the measurement are indicated):

Property	Units	Min. ¹	Max.	Test Methods ²	
Density at 15°C	[kg/m ³]	720.0	785.0	EN ISO 12185	ASTM D4052
RON	-	95.0	102.0	EN ISO 5164	ASTM D2699
MON	-	85.0	90.0	EN ISO 5163	ASTM D2700
Oxidation stability	[min]	360		EN ISO 7536	ASTM D525
Vapour pressure (DVPE)	[kPa]		100.0	EN 13016-1	ASTM D5191
Aromatics	% (V/V)		35.0	EN ISO 22854	ASTM D6839
Benzene	% (V/V)		1.0	EN ISO 22854	ASTM D6839 or D5580
Diolefins total	% (m/m)		1.0	GC-MS	HPLC
Lead	[mg/L]		5.0	ICP-OES or-EN 237	AAS
Manganese	[mg/L]		2.0	ICP-OES	AAS
Nitrogen	% (m/m)		0.2	ASTM D 4629	ASTM 5762
Olefins	% (V/V)		18.0	EN ISO 22854	ASTM D6839
Bi/Polycyclic olefins	% (m/m)		0.01	GC-MS	
Oxygen (includes 10% ethanol allowance)	% (m/m)		3.7	EN ISO 22854	EN 13132 or elemental analysis
Sulphur	[mg/kg]		10.0	EN ISO 20846	ASTM D5453
Distillation:				EN ISO 3405	ASTM D86
E at 70°C	% (V/V)	20.0	52.0		
E at 100°C	% (V/V)	46.0	72.0		
E at 150°C	% (V/V)	75.0			
Final Boiling Point	[°C]		210		
Residue	% (V/V)		2.0		
Methanol	% (V/V)		3.0		
Ethanol	% (V/V)		10.0		The only oxygenates permitted are paraffinic mono-alcohols and paraffinic mono-ethers (of 5 or more carbon atoms per molecule) with a final boiling point below 210°C.
Isopropanol	% (V/V)		12.0		
Isobutanol	% (V/V)		15.0		
tert-Butanol	% (V/V)		15.0		
Ethers (C5 or higher)	% (V/V)		22.0		
Others	% (V/V)		15.0		

Table 1 : Specifications and test methods (does not include the visual inspection)

In addition to these specifications, the appearance of the fuel, controlled by visual inspection must be clear, bright and free from solid matter and undissolved water.

The total of individual hydrocarbon components present at concentrations of less than 5% (m/m) must constitute at least 30% (m/m) of the fuel. The test method will be GC-FID (gas chromatography-flame ionisation detector) and/or GC-MS (gas chromatography-mass spectrometry).

The total concentration of naphthenes, olefins and aromatics classified by carbon number must not exceed the values given in the following table:

¹ All reported min. and max. thresholds do not include the tolerance, which needs to be calculated in accordance with ISO 4259 and taken into account to correct the min. and max. thresholds

² In case of dispute the test method listed in **bold** will be the reference

% (m/m)	C4	C5	C6	C7	C8	C9+
Naphthenes	0.1	5.0	10.0	10.0	10.0	10.0
Olefins	5.0	20.0	20.0	15.0	10.0	10.0
Aromatics			1.2	35.0	35.0	30.0

Table 2 : Naphtenes, Olefins and aromatics contents

Bicyclic and polycyclic olefins are not permitted (0.01%(m/m) max). The fuel must contain no substances which are capable of exothermic reaction in absence of external oxygen.



G. FIM SPECIFICATIONS FOR FULLY ADVANCED SUSTAINABLE FUEL, CATEGORY 3

In construction through the FIM Eco-Fuels Technical Working Group 2.
To be announced at a later stage when finalised.



H.FIM SPECIFICATIONS FOR PARTIALLY ADVANCED SUSTAINABLE FUEL, CATEGORY 4

In construction through the FIM Eco-Fuels Technical Working Group 2.
To be announced at a later stage when finalised.

I. FIM SPECIFICATIONS FOR MIXTURES OF UNLEADED FUEL(S) AND LUBRICANT

The lubricant must not:

1. change the composition of the fuel fraction when added to the fuel
2. contain any nitro-compounds, peroxides or any other engine power boosting additives
3. contribute to an improvement in overall performance in any way
4. show a reduction in mass by evaporation of more than 10% (m/m) during the distillation up to 250°C (test method: simulated distillation GC)
5. contain more than 10% of anti-knock agents (lead, manganese, iron) (test method: ICP-OES).

Moreover, the following specifications are set for the mixture of unleaded fuel(s) and lubricant:

The following properties shall be within the following thresholds (for each property, the relative test methods to be used for the measurement are indicated):

Property	Units	Min.	Max.	Test Methods	
Density at 15°C ³	[kg/m ³]	690	815	EN ISO 12185	ASTM D4052
RON	-		102	EN ISO 5164	ASTM D2699
MON	-		90	EN ISO 5163	ASTM D2700

³ For the density measurement, the min. and max. thresholds do include the tolerance



J. OXIDANT - AIR

Only ambient air may be mixed with the fuel as an oxidant.

K.FUELS CONTROLS

Please always refer to the latest regulations code in force for the discipline.

The FIM may require fuel controls, i.e. controls of the unleaded fuel, mixture of unleaded fuels or mixture of unleaded fuel and lubricant, used by riders/teams at events. These controls involve an initial sampling at the event and further testing.

1. Sampling and testing

Samples will be taken at the event either during Parc Fermé procedures, or during the session in the pitlane. The samples will be tested either:

- a) (Only in the case of a single fuel supplier) tested at the event using the GC test method.
- b) Delivered by a FIM courier to the FIM appointed laboratory for post event tests.

2. Sampling

Procedure A:

FIM fuel sampling for Gas Chromatography (GC) testing method at the event (when available, if not, procedure B applies).

1. The FIM Technical Director (or the FMNR Chief Technical Steward when there is no FIM Technical Director appointed) is the sole official responsible for the sampling management and supervision.
2. Riders/teams selected for fuel controls are directed to proceed with their vehicles to the area that has been designated for this purpose.
3. The FIM Technical Director/FMNR Chief Technical Steward collects the fuel from the motorcycle by using only new sample containers and pipettes/hand pumps.
4. The fuel is transferred through the use of the pipette/hand pump directly from the fuel tank into the vial A (designed for direct use in the GC machine).

During the total duration of this procedure, the motorcycle must remain in the appointed test area.

Procedure B:

FIM fuel sampling for the test in a FIM appointed laboratory (if Procedure A is not applicable).

1. The FIM Technical Director (or the FMNR Chief Technical Steward when there is no FIM Technical Director appointed) is the sole official responsible for the sampling management and supervision.
2. Riders/teams selected for fuel controls are directed to proceed with their vehicles to the area that has been designated for this purpose.
3. The FIM Technical Director/FMNR Chief Technical Steward collects the fuel from the motorcycle by using only new sample containers and pipettes/hand pumps.
4. The fuel is transferred through the use of the pipette/hand pump directly from the fuel tank into three containers, denominated A, B and C. The containers are closed and sealed by the FIM Technical Director/ FMNR Chief Technical Steward.

5. The FIM Technical Director/FMNR Chief Technical Steward fills in (in all its parts) and signs the Fuel Sample Declaration Form (see forms). The rider or a team representative also signs this Form, after verifying that all the information is correct.
6. The FIM Technical Director/FMNR Chief Technical Steward prepares an appropriate shipping box containing the collected A, B and C samples and a copy of the respective, signed, Fuel Sample Declaration Form. The box is then shipped to the FIM appointed laboratory by courier.

3. Testing

Procedure A:

FIM fuel testing via Gas Chromatography (GC) testing method on, during, or at the event (when available, if not, Procedure B applies).

1. One or more properties to be checked (following the relevant testing method as per Art. D, E, F, G or H) are set by the FIM for each selected rider/team.
2. The vial A must be put directly in the GC machine for GC test/analysis.
3. The threshold of result to pass the GC test is fixed at 97% of match (compared with the same batch of fuel, provided by the contracted single fuel supplier for the related discipline/championship/Cup).
4. Under 97% of match, the GC test result is failed (meaning the fuel tested is not in conformity with the fuel, provided by the contracted single fuel supplier for the related discipline/championship/Cup).
5. The full Procedure A can be made a second time upon request of the team manager (of the team which fuel is tested). The team manager can attend the full procedure.
6. There will be no protest available, only the option to immediately make a second test.
7. This result will be reported by the FIM Technical Director to the FIM nominated authorities/Officials for the related discipline/championship/Cup (e.g. FIM Stewards Panel, FIM International Jury) which will take appropriate actions.

Procedure B:

FIM fuel testing via FIM appointed laboratory (if Procedure A not available).

1. One or more properties to be checked (following the relevant testing method as per Art. D, E, F, G or H) are set by the FIM for each selected rider/team.
2. Sample A is the first sample to be tested by the FIM appointed laboratory.
3. Sample B can be used for a second analysis if required by the FIM. The test result of the A or B sample more favourable to the rider/team is taken into account. Costs for the shipping and testing of sample A and B are paid by FIM.
4. As soon as possible after completing the testing, the FIM appointed laboratory reports the test results directly to the responsible CTI Coordinator.
5. For negative cases (i.e. conformity of the tested property(ies) with the specification), the riders/teams concerned will be individually informed by the FIM in due course, copying the rider/team's FMN, the FIM Technical Director/FMNR Chief Technical Steward, the competent authority (e.g. FIM Stewards Panel, FIM International Jury), the CTI Director, the Director and Coordinator(s) of the Sporting Commission concerned.
6. Only for positive cases following testing of sample A or B or A and B (i.e. non-conformity of one or more properties*), the responsible CTI Coordinator notifies by electronic mail* the rider/team concerned (including the testing results) and, 24 hours after, forwards the relevant information to the rider/team's FMN, the FIM Technical Director/ FMNR Chief Technical Steward, the competent authority (e.g. FIM Stewards Panel, FIM International Jury), the CTI Director, the Director and Coordinator(s) of the sporting Commission concerned.

* Note: The non-conformity of one property (except the appearance) is sufficient for declaring non-conformity of the fuel or the mixture.

7. If the rider/team wishes to request a counter-expertise, he must notify the responsible CTI Coordinator by electronic mail* accordingly, within 72 hours of receipt by the FIM of the delivery status notification pertaining to the notification of the test results to the rider/team.

- If a counter-expertise is requested, the sample dedicated to the counter-expertise is sample C and the test shall aim at checking the same property(ies) previously checked on sample A/B. The rider/team can request that sample C be tested at one of the available FIM appointed laboratories. Costs for shipping and testing of sample C are paid by the rider/team concerned.

Upon notification of the sample C results, the responsible CTI Coordinator notifies by electronic mail* the rider/team concerned (including the testing results) and forwards the relevant information to the rider/team's FMN, the FIM Technical Director/ FMNR Chief Technical Steward, the competent authority (e.g. FIM Stewards Panel, FIM International Jury), the CTI Director, the Director and Coordinator(s) of the Sporting Commission concerned.

- If no counter-expertise is requested within the time limit, the responsible CTI Coordinator forwards the relevant information by electronic mail* the rider/team's FMN, the FIM Technical Director/ FMNR Chief Technical Steward), the competent authority (e.g. FIM Stewards Panel, FIM International Jury), the CTI Director, Director and Coordinator(s) of the Sporting Commission concerned.

8. The competent authority of the event concerned (e.g. FIM Stewards Panel, FIM International Jury) makes a decision based on the information received. The Coordinator of the Sporting Commission concerned notifies the rider/team concerned regarding the decision by electronic mail*.

The non-conformity of :

- A sample (in the cases B sample was not used) or
- B sample (in the cases A sample result was not conclusive) or
- A and B samples or
- A and B and C samples (in the cases B sample was used and a counter- expertise was requested) or

- A and C samples (in the cases B sample was not used and a counter- expertise was requested) automatically results in the disqualification of the rider/team from the entire event.
 - No disqualification will be applied in case of conformity of sample C.
 - Furthermore, in any case, other penalties may be applied.
- 9.** The rider/team has the right to appeal against the decision of competent authority of the event concerned (e.g. FIM Stewards Panel, FIM International Jury) in accordance with FIM Disciplinary and Arbitration Code applicable to the relevant discipline.

* The receipt of a delivery status notification will be deemed as proof of delivery.

L. FUEL SAMPLE DECLARATION FORM

		<h2 style="margin: 0;">FIM Fuel Sample Declaration Form</h2>														
Discipline																
IMN (xxx/xx)																
Rider/team's name																
Rider/team's number																
Rider/team's email or telephone number																
Team																
Vehicle's make																
Fuel's make and type																
Fuel origin (public station or race supplier)																
Fuel samples taken on date (dd/mm/yy)																
Fuel samples taken at (right before or after):																
MOTOCROSS	TRIAL	TRACK RACING	ENDURO /ISDE	RALLIES /BAJAS												
Practice <input type="checkbox"/>	Day 1 <input type="checkbox"/>	Heat n°__ <input style="width: 40px;" type="text"/>	Day 1 <input type="checkbox"/>	Day 1 <input type="checkbox"/>												
Qualifying race <input type="checkbox"/>	Day 2 <input type="checkbox"/>		Day 2 <input type="checkbox"/>	Day 2 <input type="checkbox"/>												
Race 1 <input type="checkbox"/>			Day n°__ <input type="checkbox"/>	Day n°__ <input type="checkbox"/>												
Race 2 <input type="checkbox"/>																
<table border="1" style="margin: auto; border-collapse: collapse;"> <thead> <tr> <th style="width: 15%;"></th> <th style="width: 15%;"></th> <th style="width: 70%;">Container seal n°</th> </tr> </thead> <tbody> <tr> <td style="text-align: center;">Sample A</td> <td></td> <td></td> </tr> <tr> <td style="text-align: center;">Sample B</td> <td></td> <td></td> </tr> <tr> <td style="text-align: center;">Sample C</td> <td></td> <td></td> </tr> </tbody> </table>							Container seal n°	Sample A			Sample B			Sample C		
		Container seal n°														
Sample A																
Sample B																
Sample C																
<p>The above listed details refer to fuel samples taken from the fuel tank of the motorcycle specified.</p> <p>Sample A is the first testing sample to be used by the FIM appointed laboratory</p> <p>Sample B can be used for a second analysis if required by the FIM</p> <p>Sample C is used if a counter-expertise is required by the rider/team.</p> <p>The serial numbers of the vial seals and the accuracy of the listed information have been verified.</p>																
Rider or team responsible name																
Rider or team responsible signature																
FIM Technical Director/ FMNR Chief Technical Steward name																
FIM Technical Director/ FMNR Chief Technical Steward signature																

 FIM Fuel Sample Declaration Form									
Discipline									
IMN (xxx/xx)									
Rider/team's name									
Rider/team's number									
Rider/team's email or telephone number									
Team									
Vehicle's make									
Fuel's make and type									
Fuel origin (public station or race supplier)									
Fuel samples taken on date (dd/mm/yy)									
Fuel samples taken at (right before or after):									
CIRCUIT RACING DISCIPLINES									
Free practice <input type="checkbox"/>									
Qualifying race <input type="checkbox"/>									
Warm up <input type="checkbox"/>									
Race 1 <input type="checkbox"/>									
Race 2 <input type="checkbox"/>									
<table border="1"> <thead> <tr> <th></th> <th style="text-align: center;">Container seal n°</th> </tr> </thead> <tbody> <tr> <td>Sample A</td> <td></td> </tr> <tr> <td>Sample B</td> <td></td> </tr> <tr> <td>Sample C</td> <td></td> </tr> </tbody> </table>			Container seal n°	Sample A		Sample B		Sample C	
	Container seal n°								
Sample A									
Sample B									
Sample C									
<p>The above listed details refer to fuel samples taken from the fuel tank of the motorcycle specified.</p> <p>Sample A is the first testing sample to be used by the FIM appointed laboratory</p> <p>Sample B can be used for a second analysis if required by the FIM</p> <p>Sample C is used if a counter-expertise is required by the rider/team.</p> <p>The serial numbers of the vial seals and the accuracy of the listed information have been verified.</p>									
Rider or team responsible name									
Rider or team responsible signature									
FIM Technical Director/ FMNR Chief Technical Steward name									
FIM Technical Director/ FMNR Chief Technical Steward signature									

M. LIST OF FIM CERTIFIED FUELS

Please refer to the latest list of the FIM certified fuels on the following link:

https://www.fim-moto.com/en/documents?tx_solr%5Bq%5D=certified+fuels



**FEDERATION INTERNATIONALE
DE MOTOCYCLISME**

FIM-MOTO.COM

ROUTE DE SUISSE 11 | 1295 MIES | SWITZERLAND

cti@fim.ch

6579006